

## Operating Manual

# Sound Module MSM-1 V1.00

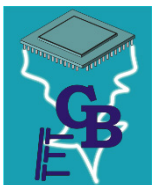

**BEIER Electronic**  
Winterbacher Str. 52/4, 73614 Schorndorf - Weiler  
Phone: 07181/46232, Fax 07181/45732  
e-mail: [modellbau@beier-electronic.de](mailto:modellbau@beier-electronic.de)  
Web: <http://www.beier-electronic.de/modellbau>

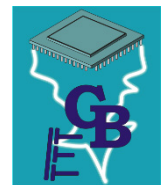

## Table of Contents

Table of Contents .....	2
Description.....	3
Safety notes.....	4
Additional information and help .....	4
Technical data .....	5
Setup – model selection .....	6
Setup – throttle and steering channel .....	8
Model no. 1 – Truck 1    ○○● .....	9
Model no. 2 – Truck 2    ○●○ .....	10
Model no. 3 – Truck 3    ○●● .....	11
Model no. 4 – Car 1    ●○○ .....	12
Model no. 5 – Car 2    ●○● .....	13
Model no. 6 – Emergency vehicle    ●●○ .....	14
Model no. 7 – Tractor    ●●● .....	15
Model no. 8 – Construction vehicle 1    ○○● .....	16
Model no. 9 – Construction vehicle 2    ○●○ .....	17
Model no. 10 – Tank 1    ○●● .....	18
Model no. 11 – Tank 2    ●○○ .....	19
Model no. 12 – Ship 1    ●○● .....	20
Model no. 13 – Ship 2    ●●○ .....	21
Model no. 14 – Ship 3    ●●● .....	22
Pin assignment.....	23
Wiring diagram .....	24
Installation of the sound module .....	25
Connection of the sound module .....	25
Controlling sounds and switching light outputs via the radio .....	30
Speaker .....	30
Volume adjustment.....	31
Control of servo output 1 on a IR light module.....	32
Status display with LEDs .....	32

## Description

The MSM-1 is a fully preconfigured sound and light module for RC models. There are 14 different model types with all sound and light settings fix stored in the memory.

You can choose from:

- 4 Trucks
- 2 Cars
- 1 Emergency vehicle
- 1 Tractor
- 2 Construction vehicles
- 3 Tanks
- 3 Ships

The different models can be easily selected using a standard RC radio (see page 6). No software, computer or other programming hardware is required to select the model. The sounds and settings of the 14 models cannot be changed on the MSM-1.

The MSM-1 has 6 proportional inputs that can evaluate 6 channels of an RC receiver. The 1st channel is always the gas/throttle channel and the 2nd channel is the steering in most models. Additional sounds and lights can be controlled via the remaining 4 channels. The sound and light functions differ depending on the model type.

To achieve various lighting effects, the MSM-1 has 8 switching outputs to which, for example, LEDs, lamps and relays can be connected. Lighting functions such as low beam, reversing lights, brake lights, turn signals, hazard lights, etc. can be controlled easily to match sound and movement.

Each of the 14 preconfigured models has its own driving sound (engine sound) and additional sounds relating to the model type. All functions can be triggered via the RC radio.

## Safety notes

- Read these operating instructions carefully before starting to use and keep them safe for future use!
- The integrated circuits on the sound module are sensitive to electrostatic charges. Therefore, do not touch these components until you have “discharged” yourself (e.g. by touching a radiator or another grounded device).
- Make sure there is adequate ventilation. The sound module can get warm.
- Protect the module from moisture and heat.
- Unfavorable placement or wiring of the module in the model may lead to a limitation in the range of the radio (mainly with 35/40 MHz radios).
- The sound module may only be operated with the supply voltages that are given in the technical data.
- Wiring may only be carried out without power supply.
- The sound module is not suitable for children under 14 years of age to use.

## Additional information and help

Do you have questions about connecting the module or need technical support?

### **BEIER Electronic Forum:**

Visit our [BEIER Electronic Forum](#). This is the best way to receive quick assistance. You can ask your questions there and receive a well-founded and tried-and-tested answer from us or other forum members. Maybe your question has already been addressed and you can find the right answer right away, for example in the [FAQ](#).

### **BEIER Electronic on Facebook:**

You can also find news and additional information about our products on Facebook under [Modellbau BEIER Electronic](#). Enthusiastic customers also found their own [BEIER Electronic Facebook group](#). As in the BEIER Electronic Forum, questions can be asked and ideas can be presented.

Technical data
----------------

<b>Supply voltage (U<sub>b</sub>):</b>	5 - 14V DC voltage
<b>Power consumption:</b>	Standby current: approx. 60 mA Operation: The current consumption depends on the volume and switched load.
<b>Proportional inputs:</b>	6 pieces PWM (1.000 – 2.000 ms)
<b>Switching outputs:</b>	8 pieces (minus switching, open collector), max. 1.5 A per output, the total current of these outputs must not exceed 3.0 A
<b>AF amplifier:</b>	20 W
<b>Recommended speakers:</b>	4 – 8 Ω
<b>Volume setting:</b>	Possible with external potentiometer (100 kΩ) and/or radio control
<b>Storage for the sound data:</b>	Internal flash 64 MB
<b>Sound output:</b>	16 bit, mono, 22 kHz
<b>Model types:</b>	14 models <ul style="list-style-type: none"> <li>• 3 x Trucks</li> <li>• 2 x Cars</li> <li>• 1 x Emergency vehicle</li> <li>• 1 x Tractor</li> <li>• 2 x Construction vehicle</li> <li>• 3 x Tanks</li> <li>• 3 x Ship</li> </ul>
<b>Available sounds:</b>	<ul style="list-style-type: none"> <li>• Driving sounds (starting sound, shutdown sound, starting sound, stopping sound, stationary sound, braking sound, reversing warning, cornering squeak, indicator sound)</li> <li>• Various additional sounds depending on the model (horn, compressed air fan, ship's horn, depth sounder, turret turning, machine gun, cannon shot, radio message, animal noises, hydraulic noise, siren, announcements)</li> </ul>
<b>Additional ports:</b>	Interface for data cable K-USB-2 (currently not working!) or IR transmitter diode for light modules LM-IR-8-1 and LM-IR-16-4
<b>Protection features:</b>	Current monitoring of the switching outputs
<b>Ambient temperature:</b>	0 – 60° C
<b>Permissible relative humidity:</b>	Max. 85 %
<b>Size:</b>	51 x 33 x 17 mm
<b>Weight:</b>	18 g

## Setup – model selection

**Attention: When activating the setup, outputs 8 of the MSM-1 may be activated! If the outputs should not be controlled for any reason, the consumers must be separated from the outputs by unplugging the ribbon cable from X3 before activating the setup.**

14 different models are stored in the MSM-1. These sound projects are fix, with all sound and light settings. No changes can be made to these model settings!

### **To choose the model, you must proceed as follows:**

1. Connect **Prop #6 (X2/6)** of the MSM-1 with a servo patch cable to a receiver channel that can be controlled via a control stick, rotary or slide control or a 3-position switch.
2. Switch on the radio and supply the receiver with voltage.
3. Apply supply voltage to the MSM-1 or switch it on → the blue LED flashes 5 times.
4. Now, within the next 5 seconds, quickly turn the control stick on the radio (Prop #6) to full deflection at least 3 times in area A (i.e. “up” or “left”) and at least 3 times in area D (i.e. “down” or “right”). This will start the setup and all 3 LEDs on the MSM-1 will flash quickly for 5 seconds.

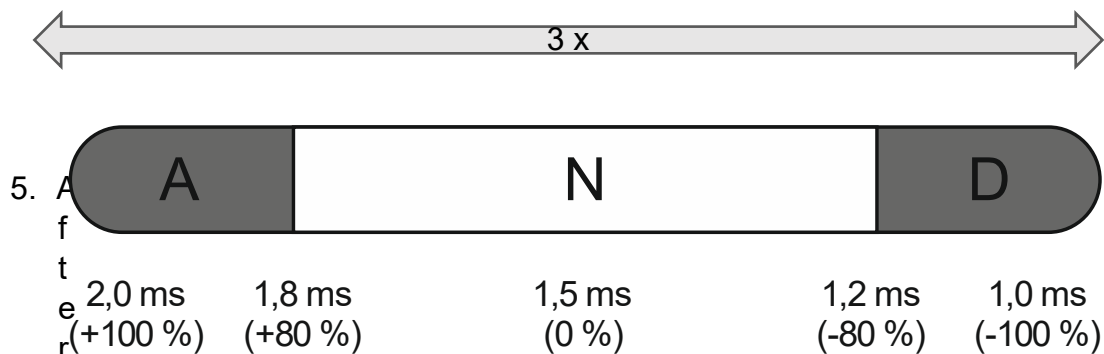

After 5 seconds, the number of the set model is displayed with the 3 LEDs on the MSM-1 (see table on the next page).

6. The number of the model can now be set using the radio. Each time the control stick is briefly tapped in areas A or D, the model number is increased or decreased by 1. The lighting or flashing of the LEDs always changes according to the number.
7. If the control stick on the radio is no longer activated for 30 seconds or the voltage on the MSM-1 is disconnected, the last model selected will be saved. The selected model remains until the setup is restarted and a different model is selected.

The selected model is indicated by 3 LEDs on the MSM-1:

Model no.	Model	LEDs
1	Truck 1	○ ○ ●
2	Truck 2	○ ● ○
3	Truck 3	○ ● ●
4	Car 1	● ○ ○
5	Car 2	● ○ ●
6	Emergency vehicle	● ● ○
7	Tractor	● ● ●
8	Construction vehicle 1	○ ○ ●
9	Construction vehicle 2	○ ● ○
10	Tank 1	○ ● ●
11	Tank 2	● ○ ○
12	Ship 1	● ○ ●
13	Ship 2	● ● ○
14	Ship 3	● ● ●

○ = LED off

◐ = LED flashes

● = LED on

## Setup – throttle and steering channel

When it comes to the signals for the speed controller, it is not clearly defined which signal value of the RC receiver represents “forward” and which value represents “reverse”. The same applies to the steering servo. A signal that means “left” for one manufacturer is “right” for another manufacturer – and vice versa.

Therefore, almost all RC radios nowadays have the option of reversing (inverting) the individual channels.

For the MSM-1, for example for the reversing light or the reversing warning, it is important to know what kind of signal the receiver emits when reversing. The same applies to the steering when activating and deactivating the indicators on the correct side.

For this reason, the MSM-1 should be taught once where “forward” and where “left” is. To do this, please carry out the following steps:

1. Connect the receiver gas/throttle channel to Prop #1.
2. Connect receiver steering channel to Prop #2.
3. Start the “Setup – Model selection” as described on page 6.
4. Wait 5 seconds until the 3 LEDs stop flashing quickly.
5. Briefly move the throttle stick from neutral to full throttle. Attention: The model starts moving and the sound is activated!
6. Briefly move the steering stick from neutral to the maximum left.
7. Either wait 30 seconds until the setup ends automatically or disconnect the MSM-1 from the power supply. This will save the settings.



Model no. 1 – Truck 1



#### Assignment of prop. inputs:

	A - short	A - long	D - short	D - long
<b>Prop #1</b>	Gas/throttle channel			
<b>Prop #2</b>	Steering channel (indicator)			
<b>Prop #3</b>	Horn 1		Horn 2	
<b>Prop #4</b>	Fanfare 1	Fanfare 2	Fanfare 3	IR servo
<b>Prop #5</b>	Turk's whistle	Volume setting	Compressed air	Hazard lights
<b>Prop #6</b>	Light 1	Light 2	Light 3	Light 4

#### Assignment of outputs:

1	2	3	4	5	6	7	8
Light 1	Light 2	Light 3	Light 4	Left indicator	Right indicator	Brake light	Reversing light

#### Additional model features:

- The driving sound is switched on automatically when accelerating (Prop #1) and off again after 30 s when stationary.
- The indicators are activated via the steering (Prop #2). If the indicators are not to be activated via the steering, but rather via an extra switch on the radio, then the steering servo is connected directly to the receiver. Prop #2 of the MSM-1 is then connected to the receiver channel of the radio switch that controls the indicator lights.
- When braking, the brake light is activated. In addition, the brake light is always on when stationary as long as the driving sound is on.
- When reversing, the reversing lights, hazard warning lights and reversing warning sound are switched on automatically.
- If the "IR Servo" function is activated, the servo output 1 of the IR light modules [LM-IR-8-1](#) and [LM-IR-16-4](#) can be controlled via Prop #2. See page 32.

Model no. 2 – Truck 2



#### Assignment of prop. inputs:

	A - short	A - long	D - short	D - long
<b>Prop #1</b>	Gas/throttle channel			
<b>Prop #2</b>	Steering channel (indicator)			
<b>Prop #3</b>	Horn 1		Horn 2	
<b>Prop #4</b>	Fanfare 1	Fanfare 2	Fanfare 3	IR servo
<b>Prop #5</b>	Turk's whistle	Volume setting	Compressed air	Hazard lights
<b>Prop #6</b>	Light 1	Light 2	Light 3	Light 4

#### Assignment of outputs:

1	2	3	4	5	6	7	8
Light 1	Light 2	Light 3	Light 4	Left indicator	Right indicator	Brake light	Reversing light

#### Additional model features:

- The driving sound is switched on automatically when accelerating (Prop #1) and off again after 30 s when stationary.
- The indicators are activated via the steering (Prop #2). If the indicators are not to be activated via the steering, but rather via an extra switch on the radio, then the steering servo is connected directly to the receiver. Prop #2 of the MSM-1 is then connected to the receiver channel of the radio switch that controls the indicator lights.
- When braking, the brake light is activated. In addition, the brake light is always on when stationary as long as the driving sound is on.
- When reversing, the reversing lights, hazard warning lights and reversing warning sound are switched on automatically.
- If the "IR Servo" function is activated, the servo output 1 of the IR light modules [LM-IR-8-1](#) and [LM-IR-16-4](#) can be controlled via Prop #2. See page 32.

## Model no. 3 – Truck 3

**Assignment of prop. inputs:**

	A - short	A - long	D - short	D - long
<b>Prop #1</b>	Gas channel			
<b>Prop #2</b>	Steering channel (indicator)			
<b>Prop #3</b>	Horn 1		Horn 2	
<b>Prop #4</b>	Fanfare 1	Fanfare 2	Fanfare 3	IR servo
<b>Prop #5</b>	Turk's whistle	Volume setting	Compressed air	Hazard lights
<b>Prop #6</b>	Light 1	Light 2	Light 3	Light 4

**Assignment of outputs:**

1	2	3	4	5	6	7	8
Light 1	Light 2	Light 3	Light 4	Left indicator	Right indicator	Brake light	Reversing light

**Additional model features:**

- The driving sound is switched on automatically when accelerating (Prop #1) and off again after 30 s when stationary.
- The indicators are activated via the steering (Prop #2). If the indicators are not to be activated via the steering, but rather via an extra switch on the radio, then the steering servo is connected directly to the receiver. Prop #2 of the MSM-1 is then connected to the receiver channel of the radio switch that controls the indicator lights.
- When braking, the brake light is activated. In addition, the brake light is always on when stationary as long as the driving sound is on.
- When reversing, the reversing lights, hazard warning lights and reversing warning sound are switched on automatically.
- If the "IR Servo" function is activated, the servo output 1 of the IR light modules [LM-IR-8-1](#) and [LM-IR-16-4](#) can be controlled via Prop #2. See page 32.

Model no. 4 – Car 1	● ○ ○
---------------------	-------

**Assignment of prop. inputs:**

	A - short	A - long	D - short	D - long
<b>Prop #1</b>	Gas channel			
<b>Prop #2</b>	Steering channel (indicator)			
<b>Prop #3</b>	Horn 1		Horn 2	
<b>Prop #4</b>	Turk's whistle	Music 1	Fanfare	Music 2
<b>Prop #5</b>	Chirp	Volume setting	Door open/close	Hazard lights
<b>Prop #6</b>	Light 1	Light 2	Light 3	Light 4

**Assignment of outputs:**

1	2	3	4	5	6	7	8
Light 1	Light 2	Light 3	Light 4	Left indicator	Right indicator	Brake light	Reversing light

**Additional model features:**

- The driving sound is switched on when accelerating (Prop #1) and off again after 30 s when stationary.
- The indicators are activated via the steering (Prop #2). If the indicators are not to be activated via the steering, but rather via an extra switch on the radio, then the steering servo is connected directly to the receiver. Prop #2 of the MSM-1 is then connected to the receiver channel of the radio switch that controls the indicator lights
- When braking, the brake light is activated. In addition, the brake light is always on when stationary as long as the driving sound is on.
- When reversing, the reversing lights is switched on automatically.

Model no. 5 – Car 2



#### Assignment of prop. inputs:

	A - short	A - long	D - short	D - long
<b>Prop #1</b>	Gas channel			
<b>Prop #2</b>	Steering channel (indicator)			
<b>Prop #3</b>	Horn 1		Horn 2	
<b>Prop #4</b>	Turk's whistle	Music 1	Fanfare	Music 2
<b>Prop #5</b>	Chirp	Volume setting	Door open/close	Hazard lights
<b>Prop #6</b>	Light 1	Light 2	Light 3	Light 4

#### Assignment of outputs:

1	2	3	4	5	6	7	8
Light 1	Light 2	Light 3	Light 4	Left indicator	Right indicator	Brake light	Reversing light

#### Additional model features:

- The driving sound is switched on when accelerating (Prop #1) and off again after 30 s when stationary.
- The indicators are activated via the steering (Prop #2). If the indicators are not to be activated via the steering, but rather via an extra switch on the radio, then the steering servo is connected directly to the receiver. Prop #2 of the MSM-1 is then connected to the receiver channel of the radio switch that controls the indicator lights
- When braking, the brake light is activated. In addition, the brake light is always on when stationary as long as the driving sound is on.
- When reversing, the reversing lights is switched on automatically.

## Model no. 6 – Emergency vehicle



### Assignment of prop. inputs:

	A - short	A - long	D - short	D - long
<b>Prop #1</b>	Gas channel			
<b>Prop #2</b>	Steering channel (indicator)			
<b>Prop #3</b>	Horn 1		Horn 2	
<b>Prop #4</b>	Martinshorn 1	Martinshorn 2	Martinshorn 3	Martinshorn 4
<b>Prop #5</b>	Announcement 1	Volume setting	Announcement 2	Hazard lights
<b>Prop #6</b>	Light 1	Light 2	Warning light	Flashing light

### Assignment of outputs:

1	2	3	4	5	6	7	8
Light 1	Light 2	Warning light	Flashing light	Left indicator	Right indicator	Brake light	Reversing light

### Additional model features:

- The driving sound is switched on when accelerating (Prop #1) and off again after 30 s when stationary.
- The indicators are activated via the steering (Prop #2). If the indicators are not to be activated via the steering, but rather via an extra switch on the radio, then the steering servo is connected directly to the receiver. Prop #2 of the MSM-1 is then connected to the receiver channel of the radio switch that controls the indicator lights
- When braking, the brake light is activated. In addition, the brake light is always on when stationary as long as the driving sound is on.
- When reversing, the reversing lights and hazard warning lights are switched on automatically.
- When the siren is switched on, the “warning light” and “speed camera” outputs are automatically switched on.
- If the warning light and/or speed camera was activated before the siren was switched on, these outputs remain switched on even after the siren has been switched off again.

Model no. 7 – Tractor	
-----------------------	---

**Assignment of prop. inputs:**

	A - short	A - long	D - short	D - long
<b>Prop #1</b>	Gas channel			
<b>Prop #2</b>	Faucet	goose	Cow	Dog
<b>Prop #3</b>	Horn 1		Horn 2	
<b>Prop #4</b>	Cricket	Plow	Bird 1	Bird 2
<b>Prop #5</b>	Left indicator	Volume setting	Right indicator	Hazard lights
<b>Prop #6</b>	Light 1	Light 2	Light 3	Light 4

**Assignment of outputs:**

1	2	3	4	5	6	7	8
Light 1	Light 2	Light 3	Light 4	Left indicator	Right indicator	Brake light	Reversing light

**Additional model features:**

- The driving sound is switched on when accelerating (Prop #1) and off again after 30 s when stationary.
- When braking, the brake light is activated. In addition, the brake light is always on when stationary as long as the driving sound is on.
- When reversing, the reversing light is automatically switched on.

Model no. 8 – Construction vehicle 1	○○●
--------------------------------------	-----

**Assignment of prop. inputs:**

	A - short	A - long	D - short	D - long
<b>Prop #1</b>	Gas channel			
<b>Prop #2</b>	Steering channel			
<b>Prop #3</b>	Horn 1		Horn 2	
<b>Prop #4</b>	Hydraulic sound		Hydraulic sound	
<b>Prop #5</b>	Left indicator	Volume setting	Right indicator	Hazard lights
<b>Prop #6</b>	Light 1	Light 2	Warning light quickly	Warning light slow

**Assignment of outputs:**

1	2	3	4	5	6	7	8
Light 1	Light 2	Warning light quickly	Warning light slow	Left indicator	Right indicator	Brake light	Reversing light

**Additional model features:**

- The driving sound is switched on when accelerating (Prop #1) and off again after 30 s when stationary.
- The indicators are switched on manually (Prop #5) and can also be switched off manually, otherwise the indicators are automatically switched off after a steering operation (Prop #2).
- When braking, the brake light is activated. In addition, the brake light is always on when stationary as long as the driving sound is on.
- When reversing, the reversing lights and reversing warning tone are switched on automatically.



Model no. 9 – Construction vehicle 2	○ ● ○
--------------------------------------	-------

**Assignment of prop. inputs:**

	A - short	A - long	D - short	D - long
<b>Prop #1</b>	Gas channel			
<b>Prop #2</b>	Steering channel			
<b>Prop #3</b>	Horn 1		Horn 2	
<b>Prop #4</b>	Hydraulic sound		Hydraulic sound	
<b>Prop #5</b>	Left indicator	Volume setting	Right indicator	Hazard lights
<b>Prop #6</b>	Light 1	Light 2	Warning light quickly	Warning light slow

**Assignment of outputs:**

1	2	3	4	5	6	7	8
Light 1	Light 2	Warning light quickly	Warning light slow	Left indicator	Right indicator	Brake light	Reversing light

**Additional model features:**

- The driving sound is switched on when accelerating (Prop #1) and off again after 30 s when stationary.
- The indicators are switched on manually (Prop #5) and can also be switched off manually, otherwise the indicators are automatically switched off after a steering operation (Prop #2)
- When braking, the brake light is activated. In addition, the brake light is always on when stationary as long as the driving sound is on.
- When reversing, the reversing lights and reversing warning tone are switched on automatically.

Model no. 10 – Tank 1



**Assignment of prop. inputs:**

	A - short	A - long	D - short	D - long
Prop #1	Gas channel			
Prop #2	Steering channel			
Prop #3	MG1		Shot 1	Shot 2
Prop #4	Tower turning		Tower turning	
Prop #5	MG2	Volume setting	Radio message 1	Radio message 2
Prop #6	Light 1	Light 2	Light 3	Light 4

**Assignment of outputs:**

1	2	3	4	5	6	7	8
Light 1	Light 2	Light 3	Light 4	Cannon Flash	MG flash	Brake light	Reversi ng light

**Additional model features:**

- The driving sound is switched on when accelerating (Prop #1) and off again after 30 s when stationary.
- When braking, the brake light is activated. In addition, the brake light is always on when stationary as long as the driving sound is on.
- When reversing, the reversing light is automatically switched on.

Model no. 11 – Tank 2



**Assignment of prop. inputs:**

	A - short	A - long	D - short	D - long
<b>Prop #1</b>	Gas channel			
<b>Prop #2</b>	Steering channel			
<b>Prop #3</b>	MG1		Shot 1	Shot 2
<b>Prop #4</b>	Tower turning		Tower turning	
<b>Prop #5</b>	MG2	Volume setting	Radio message 1	Radio message 2
<b>Prop #6</b>	Light 1	Light 2	Light 3	Light 4

**Assignment of outputs:**

1	2	3	4	5	6	7	8
Light 1	Light 2	Light 3	Light 4	Cannon Flash	MG flash	Brake light	Reversi ng light

**Additional model features:**

- The driving sound is switched on when accelerating (Prop #1) and off again after 30 s when stationary.
- When braking, the brake light is activated. In addition, the brake light is always on when stationary as long as the driving sound is on.
- When reversing, the reversing light is automatically switched on.

Model no. 12 – Ship 1



**Assignment of prop. inputs:**

	A - short	A - long	D - short	D - long
<b>Prop #1</b>	Gas channel			
<b>Prop #2</b>	Bell jar	Ship's horn 3	Ship's horn 4	Ship's horn 5
<b>Prop #3</b>	Ship's horn 1		Ship's horn 2	
<b>Prop #4</b>	Light 1	Light 2	Light 3	Light 4
<b>Prop #5</b>	Seagulls	Volume setting	Echo sounder	Anchor chain
<b>Prop #6</b>	Light 5	Light 6	Warning light	Double flash

**Assignment of outputs:**

1	2	3	4	5	6	7	8
Light 1	Light 2	Light 3	Light 4	Light 5	Light 6	Warning light	Double flash

**Additional model features:**

- The driving sound is switched on when accelerating (Prop #1) and off again after 30 s when stationary.

Model no. 13 – Ship 2



**Assignment of prop. inputs:**

	A - short	A - long	D - short	D - long
<b>Prop #1</b>	Gas channel			
<b>Prop #2</b>	Bell jar	Ship's horn 3	Ship's horn 4	Ship's horn 5
<b>Prop #3</b>	Ship's horn 1		Ship's horn 2	
<b>Prop #4</b>	Light 1	Light 2	Light 3	Light 4
<b>Prop #5</b>	Seagulls	Volume setting	Echo sounder	Anchor chain
<b>Prop #6</b>	Light 5	Light 6	Warning light	Double flash

**Assignment of outputs:**

1	2	3	4	5	6	7	8
Light 1	Light 2	Light 3	Light 4	Light 5	Light 6	Warning light	Double flash

**Additional model features:**

- The driving sound is switched on when accelerating (Prop #1) and off again after 30 s when stationary.

Model no. 14 – Ship 3



**Assignment of prop. inputs:**

	A - short	A - long	D - short	D - long
<b>Prop #1</b>	Gas channel			
<b>Prop #2</b>	Bell jar	Ship's horn 3	Ship's horn 4	Ship's horn 5
<b>Prop #3</b>	Ship's horn 1		Ship's horn 2	
<b>Prop #4</b>	Light 1	Light 2	Light 3	Light 4
<b>Prop #5</b>	Seagulls	Volume setting	Echo sounder	Anchor chain
<b>Prop #6</b>	Light 5	Light 6	Warning light	Double flash

**Assignment of outputs:**

1	2	3	4	5	6	7	8
Light 1	Light 2	Light 3	Light 4	Light 5	Light 6	Warning light	Double flash

**Additional model features:**

- The driving sound is switched on when accelerating (Prop #1) and off again after 30 s when stationary.

## Pin assignment

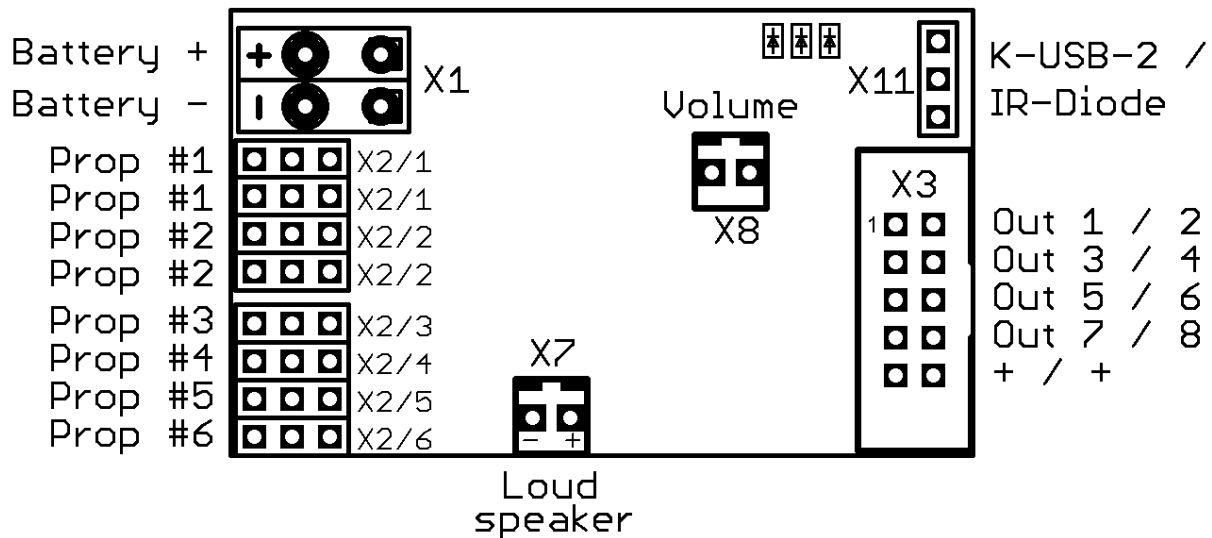

<b>X1/1</b>	Battery + (5 – 14 V)
<b>X1/2</b>	Battery -
<b>X2/1</b>	Proportional input #1 (gas/throttle channel)
<b>X2/2</b>	Proportional input #2 (steering or 2nd throttle channel)
<b>X2/3</b>	Proportional input #3
<b>X2/4</b>	Proportional input #4
<b>X2/5</b>	Proportional input #5
<b>X2/6</b>	Proportional input #6
<b>X3</b>	Switching outputs 1 - 8
<b>X7</b>	Speaker
<b>X8</b>	Potentiometer for volume adjustment
<b>X11</b>	Data cable K-USB-2 (optional, currently not functional!) or IR transmitter diode for light module LM-IR-8-1 or LM-IR-16-4

# Wiring diagram

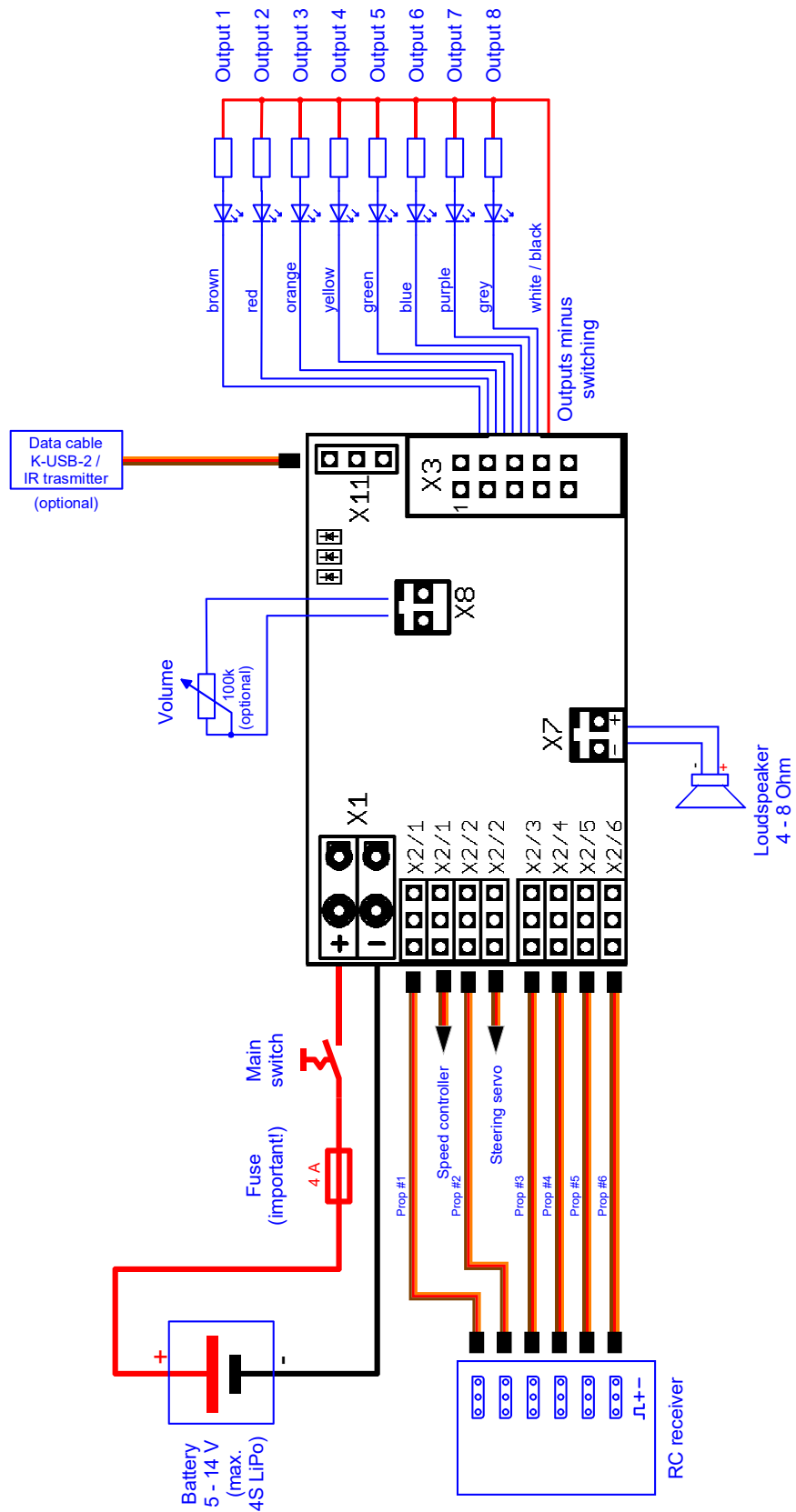



## Installation of the sound module

To securely attach the sound module to the model, you can use self-adhesive Velcro tape, which can be attached to the plastic cover of the MSM-1. When installing the module, make sure that no components or conductor tracks on the circuit board touch metal parts! This can lead to short circuits that can destroy the sound module and devices connected to it.

## Connection of the sound module

**Always carry out all connection work with the supply voltage switched off!**

The gray 2-pin terminal block X1 is a spring-loaded terminal that allows the sound module to be connected quickly and easily. To clamp or unclamp a cable, simply press the clamp's operating lever from above with a small screwdriver. This opens the clamp and the cable can be plugged in or unplugged. The cables should be stripped of approx. 7 – 8 mm of insulation and ideally tinned before connecting.

### **Connection of the supply voltage (battery):**

The sound module is designed for a DC voltage of 5 – 14 V. The positive pole is connected to terminal X1/1 and the negative pole of the supply voltage is connected to terminal X1/2. The cable cross section should be as large as possible (0.75 mm<sup>2</sup> - 1.5 mm<sup>2</sup>).

**It is important to pay attention to the correct polarity of the supply voltage!  
Reverse polarity can destroy the sound module!!!**

The driving battery is usually used as the power supply. Ideally, use a suitable Y-cable for the connection in order to supply the speed controller and sound module with voltage from the battery at the same time.

**If another battery is used as power supply for the sound module and not the driving battery, then the negative poles of the two batteries should also be connected to each other! This avoids any disruptions that may occur.**

If the supply voltage has been connected correctly, the green LED on the module lights up.

We strongly recommend installing the supplied fuse (4 A) in the positive cable of the sound module, to avoid a major damage of your model and the sound module in the event of an incorrect wiring or a defect.

Unfortunately, a fuse can never 100% protect all incorrect connections! Therefore, please make sure that everything is connected correctly.

In addition, a switch can also be connected to the plus line of the supply voltage to switch off the entire sound module. This has the advantage of lower power consumption if no sound is needed for a long time. However, the light outputs of the module do not work either!

**If the power supply to the speed controller is to be disconnected from the battery (e.g. for tests without a drive), the plus cable of the battery must always be disconnected first (or plus and minus at the same time)!  
Never disconnect the negative cable first (or only)!**

### **Connecting the speaker:**

The loudspeaker is connected to the MSM-1 in connector X7 (white).

The red cable of the speaker connection cable is connected to the positive pole of the speaker, the black cable to the negative pole of the speaker. If it is not clear which connection is plus or minus on the speaker, the connection cables can be attached anywhere.

If possible, the connection cable supplied for the loudspeaker should not be extended in order to avoid interference with the receiver (especially with FM systems)! The speaker cable should also be laid as far away as possible from the receiver and the antenna.

### **Notes on the power supply for the receiver:**

The voltage at terminals X1/1 and X1/2 only supplies the LF amplifier for the sound output, the switching outputs and the remaining internal electronics of the sound module with power.

The receiver is not supplied with this voltage. But it doesn't matter to the sound module if, for example, a voltage comes in to X2 via a BEC or a receiver battery.

A BEC voltage from the speed controller is passed on directly to the receiver via the X2 connections.

The receiver power supply can be planned in the same way as if no sound module were connected at all. So, for example, if there are 2 speed controllers with BEC, one BEC must be deactivated.

**Connection of switching outputs 1 - 8:**

The outputs 1 - 8 of the module are on the pin connector X3.

The supplied [ribbon cable](#) one can be used to connect the outputs. For easier connection, we also offer connection terminal clamps [AKL-8](#) and [AKL-8-W](#) in our shop.

Of course, other cables/plugs can also be connected to the pins of X3. A cable cross section of 0.14 mm<sup>2</sup> - 0.5 mm<sup>2</sup> should be used for the switching outputs.

The sound module always switches the negative pole to the connected load for all outputs. The negative pole of the load is connected to the output of the sound module (see connection diagram).

The common positive pole for outputs 1 – 8 are the black and white wires. It is also possible to connect the load directly to the positive terminal of the battery.

**Assignment of the ribbon cable:**

Output	Ribbon cable (X3)
1	brown
2	red
3	orange
4	yellow
5	green
6	blue
7	purple
8	gray
positive pole	white
positive pole	black

The voltage on the positive pins of X3 is as high as the module's supply voltage.

If LEDs are connected, series resistors must always be used. It doesn't matter whether the series resistors are connected to the plus or minus line.

The correct polarity is important for LEDs, otherwise they will not light up.

The series resistors required for the LEDs depend on the LED colors and the LED current. For orientation purposes, here is a table with series resistors for standard LEDs (current approx. 15 mA) as a rough guide:

Supply voltage	series resistance
6V	270 ohms
7.2V	330 ohms
8.4V	470 ohms
9.6V	510 ohms
12V	680 ohms

There are also LED series resistor calculators on the Internet (e.g [www.leds.de/widersrechner](http://www.leds.de/widersrechner)), with which the ideal resistance can be calculated quickly and easily.

#### **Connection of the data cable K-USB-2:**

The data cable [K-USB-2](#) is connected to connector X11. The brown wire of the servo cable points towards the edge of the board.

The sound module is not supplied with voltage via the data cable. If the data cable is to be used, the MSM-1 must be supplied with voltage via the battery as normal.

The data cable is currently not working. It may be possible to use this later to carry out firmware updates or live diagnostics.

#### **Connecting an IR transmitter diode:**

As an alternative to the data cable, an IR transmitter diode can also be connected to X11 to transmit the states of the 8 outputs to the IR light modules [LM-IR-8-1](#) and [LM-IR-16-4](#).

However, at [LM-IR-16-4](#) only outputs 1 – 8 and servo output 1 can be controlled on the light module. It is not possible to control outputs 9 - 16, servo outputs 2 - 4 or the motor output of the light module [LM-IR-16-4](#) with the MSM-1!

#### **General information about wiring in the model:**

Cables with a cross section of at least 0.75 mm<sup>2</sup> should be used to connect the supply voltage. For all other connections, thinner cables of 0.14 mm<sup>2</sup> to 0.5 mm<sup>2</sup> are sufficient.

It is also important to ensure that cables are laid as “cleanly” as possible, i.e. to use short cables and not to lay unnecessary loops.

### **Connection of the proportional inputs**

Up to 6 proportional channels of an RC receiver can be connected to the pins X2/1 – X2/6. The 6 supplied servo patch cables are used for the connection.

The 6 proportional inputs are marked on the cover of the sound module. Prop #1 and #2 are each designed twice so that the proportional signal can be passed on to the speed controller or steering servo.

The servo patch cables are plugged onto the sound module so that the brown cable points to the edge of the board and the orange cable points to the center of the board.

Prop #1 (X2/1) is always the gas channel. A connection to the gas channel of the receiver must be established here. The servo cable of the speed controller is plugged into the 2nd connection of Prop #1.

Prop #2 (X2/2) is the steering channel on most model types. The first connection of Prop #2 is connected to the steering channel of the receiver. The steering servo plugs into the 2nd port of Prop #2.

The channel numbers of the sound module (Prop #1 - #6) are not related to the channel numbers of the receiver. Channel #1 of the receiver does not necessarily have to be connected to Prop #1 of the sound module. If the control stick for accelerating, for example on the receiver, is on channel #3, then channel #3 of the receiver is connected to prop #1 of the sound module.

The neutral positions of Prop #1 and Prop #2 are re-read from the receiver every time the MSM-1 is switched on. It is important to ensure that the throttle and steering are in neutral position when the model is switched on or the battery is plugged in. The neutral positions of Prop #3 – Prop #6 are fixed at 1,500 ms. This is the standard value for current remote controls.

If the speed controller has a BEC (a power supply for the receiver), the BEC voltage is forwarded from the speed controller to the receiver via connectors X2/1 or X2/2.

## Controlling sounds and switching light outputs via the radio

Depending on the model type, various additional sounds are triggered on the sound module via the proportional inputs Prop #2 – Prop #6. Outputs can also be switched for different lights. See model descriptions starting on page 9.

Toggle switches/buttons with 3 positions are preferably used on the RC radio. Furthermore, proportional controls such as sticks, rotary controls or sliders can also be used. However, switches with only 2 positions are not suitable and cannot be used to control all functions.

The functions are triggered when the encoder is brought to areas A or D for a short time (less than 2 seconds) or a long time (longer than 2 seconds). Up to 4 different functions are possible for each proportional input. Depending on the radio, it is possible that the positions of A and D are swapped.

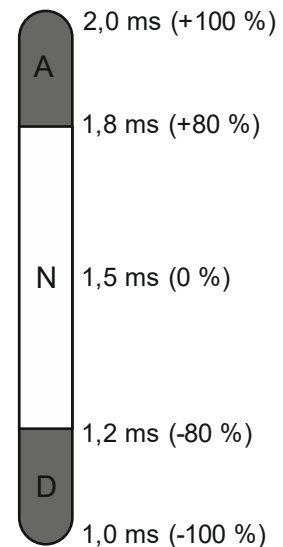

## Speaker

A loudspeaker that has an impedance of at least 4  $\Omega$  and a power of at least 8 W can be connected to the MSM-1 sound module. We recommend using a full-range speaker with 4  $\Omega$  or 8  $\Omega$ . Speakers with a higher impedance also work, but the volume decreases with higher impedance.

The maximum power and thus the volume of the sound module depends, in addition to the impedance, also somewhat on the level of the supply voltage.

In order to achieve optimal volume and sound quality, the loudspeaker should be installed in a suitable resonance box (speaker box). In any case, it should be avoided that air passes unhindered from the front of the membrane to the back (acoustic short circuit).

Every amplifier output stage generates a certain amount of heat due to power loss, which must be dissipated into the ambient air. In general, care should always be taken to ensure that heat dissipation (air circulation) is as good as possible in the area of the sound module. Particularly at higher voltages (e.g. over 9.6 V), active cooling of the sound module with a small fan may be necessary.

If the output power of the sound module is not sufficient despite the high output, an additional amplifier can be connected to the input of the amplifier using a level adapter with galvanic isolation (often used at car radios) and a small capacitor (10 nF).

## Volume adjustment

There are 2 ways to adjust the volume of the MSM-1:

1. Via a volume potentiometer (100 k $\Omega$ ) at connector X8 (brown)
2. With the RC radio control (Prop #5)

Both variants also work in parallel, but it must be noted that a low volume always has priority. This means that if, for example, the volume is turned to zero using the volume potentiometer, it cannot be increased again via the radio. The same applies to the other case: If the volume is set to low via the radio, then the volume cannot be increased using the volume potentiometer.

Therefore, adjusting the volume using the volume potentiometer and the radio at the same time is not recommended.

The volume potentiometer is not included, it can be purchased as an accessory in our [online shop](#).

### **Procedure for adjusting the volume via the radio:**

1. First, the volume setting must be activated. This is done by bringing Prop #5 into area A for at least 2 seconds.
2. If the volume setting is active, the blue LED on the MSM-1 lights up as an identification symbol. If the driving sound is not on when you activate the volume setting, it will be switched on, as it usually only makes sense to adjust the volume if you can actually hear the sound.
3. Now the volume can be increased by moving Prop #5 to area A. Area D of Prop #5 reduces volume.
4. If the volume does not change for 5 seconds, it will be saved and the volume setting will be exited.

During volume adjustment, the normal functions (switching sounds or outputs) of Prop #5 are disabled.

## Control of servo output 1 on a IR light module

For models no. 1 - 3 (trucks) it is also possible to control servo output 1 of the light modules [LM-IR-8-1](#) and [LM-IR-16-4](#) via IR transmission. For example, trailer support legs can be controlled via a speed controller that is connected to servo output 1.

However, the control of the IR servo output must first be temporarily activated using the "IR servo" function. This is done by placing Prop #4 in the "D" area for longer than 2 seconds. The hazard warning lights flash quickly to indicate that the IR servo control is active.

Now servo output 1 can be controlled proportionally via Prop #2 (steering channel). However, if a steering servo is connected to Prop #2, the steering servo will also move with it! Control of the IR servo output is only possible when the model is stationary, i.e. the gas channel is in neutral position.

To deactivate the IR servo control again, Prop #4 must be brought into the "D" area again for longer than 2 seconds. The servo output on the IR light module then goes to neutral (center). The hazard lights stop flashing quickly and Prop #2 goes back to just controlling the steering servo and the turn signals.

## Status display with LEDs

There are 3 LEDs on the sound module that show the status or the different states of the sound module.

As soon as the MSM-1 is connected to the power supply (X1/1 and X1/2), the green LED lights up.

During model selection (setup), the 3 LEDs indicate the selected model type. See page 6.

Error code	Status or error	LED green	LED red	LED blue	What to do?
0	Everything OK, module is ready for operation	on	off	off	-
12	Amplifier error	on	12 slow flashes	off	Contact BEIER-Electronic
15	Overcurrent detected at switching outputs	on	on	off	Check the connection of the switching outputs, check the total current of all outputs
16	Undervoltage detected (less than 4.5 V)	on	off	slow blinking	Check battery voltage and charge battery if necessary



**Note on disposal:**

Retired electrical and electronic equipment contains a variety of valuable resources, including precious metals and critical raw materials. Achieving a high collection and recycling rate and the associated return of these raw materials into the production cycle is one of the central goals of the environmentally friendly and sustainable disposal of electrical and electronic devices.

For this reason, our modules must not be disposed of with normal household waste, but must be collected separately. Municipal collection points such as recycling centers can be used for this. Larger retailers also offer take-back points that can be used even if the product was not purchased there. We are happy to take care of the professional disposal free of charge. To do this, send the module back to us with sufficient postage (!!!). Personal data must be deleted on your own responsibility before disposal.

