



JXMODEL

# JXmodel F2000

4X2 1/14 SCALE R/C



# 推荐工具

## RECOMMENDATION TOOL

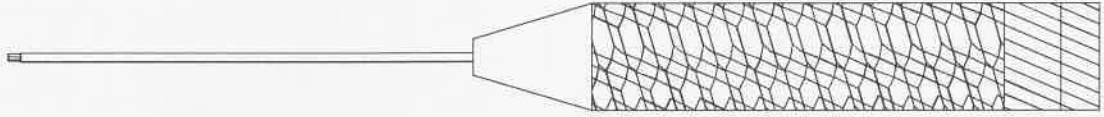

内六角螺丝刀 十字螺丝刀

HEX DRIVERS 1.5MM 2.0MM 2.5MM

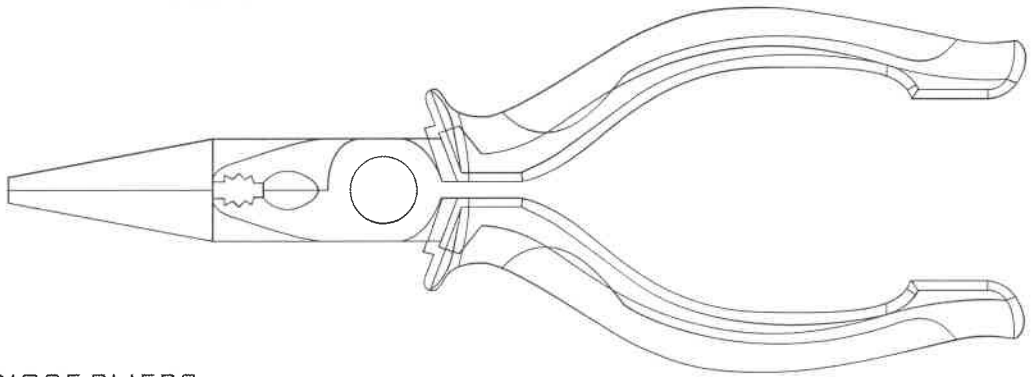

尖嘴钳

LONG NOSE PLIERS



套筒(原厂配有)

WRENCH 2.0MM

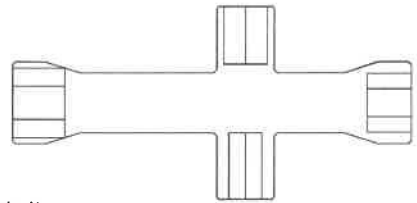

十字套筒

CROSS WRENCH

## 安装提示

### TIPS FOR ASSEMBLY

- 合金工艺制品存在一定的毛刺瑕疵属正常现象，用户需自行打磨  
IT IS NORMAL THAT THERE ARE SOME BURR DEFECTS IN ALLOY PROCESS PRODUCTS. USERS NEED TO POLISH THEM BY THEMSELVES
- 合金制品表面经打沙处理，用户涂装前先清理好产品上的油污、尘埃  
THE SURFACE OF ALLOY PRODUCTS SHALL BE SANDED, AND THE OIL AND DUST ON THE PRODUCTS SHALL BE CLEANED BEFORE COATING
- 合金制品涂装建议先喷环氧底漆、或者金属模型水补土油漆，再上色漆  
IT IS RECOMMENDED TO SPRAY EPOXY PRIMER OR METAL MODEL WATER PAINT BEFORE PAINTING ALLOY PRODUCTS
- 使用好质量的螺丝刀，避免磨损螺丝头  
USE GOOD QUALITY HEX DRIVERS TO AVOID STRIPPING SCREW HEADS
- 当将金属螺丝拧进金属部件时，请使用螺纹胶  
USE THREAD LOCK WHEN PUTTING METAL SCREWS INTO METAL PARTS
- 不要将螺丝拧太紧，否则将会磨损螺纹  
DO NOT OVER TIGHTEN SCREWS OTHERWISE YOU MAY STRIP THE THREAD

# 1 JXmodel

M3X6半圆头  
x8

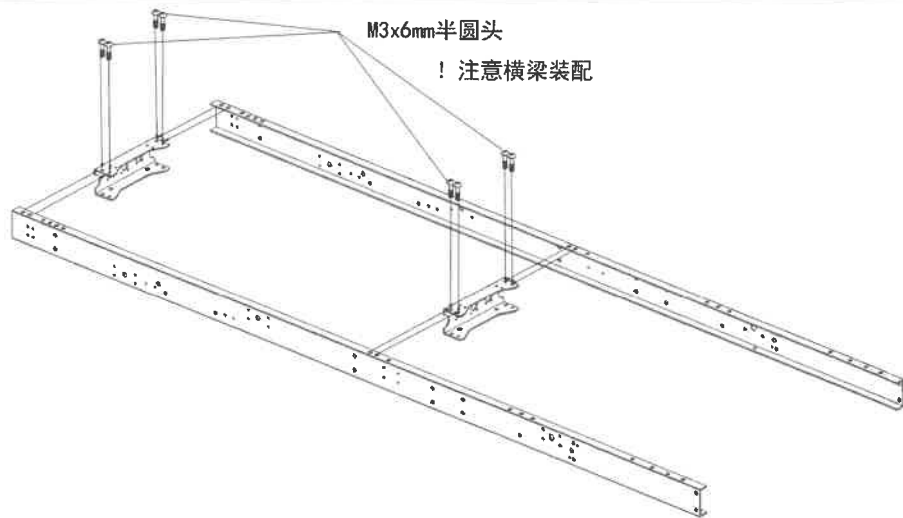

# 2 JXmodel

- M2x6杯头 x8
- M3X5半圆头 x8
- M3x6半圆头 x4
- MP-11 x2
- MP-38 x1
- MP-39 x2
- MP-40 x1

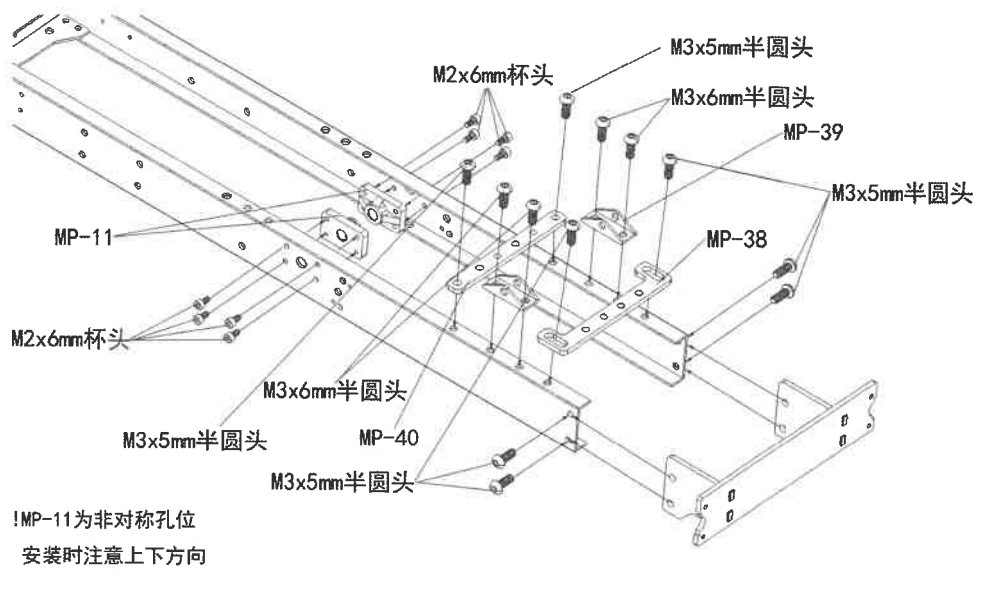

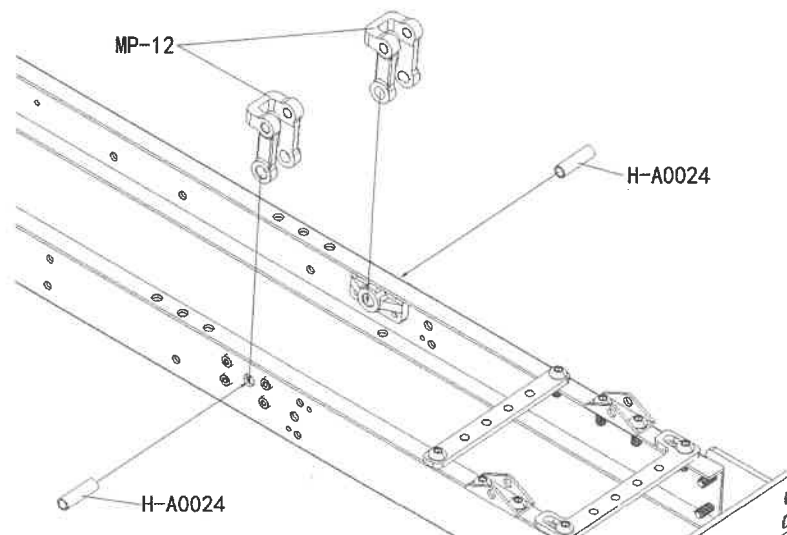

# 3 JXmodel

- MP-12 x2
- H-A0024 x2



# 4 JXmodel

 2mm E型卡簧  
x2

 H-A0023  
x2

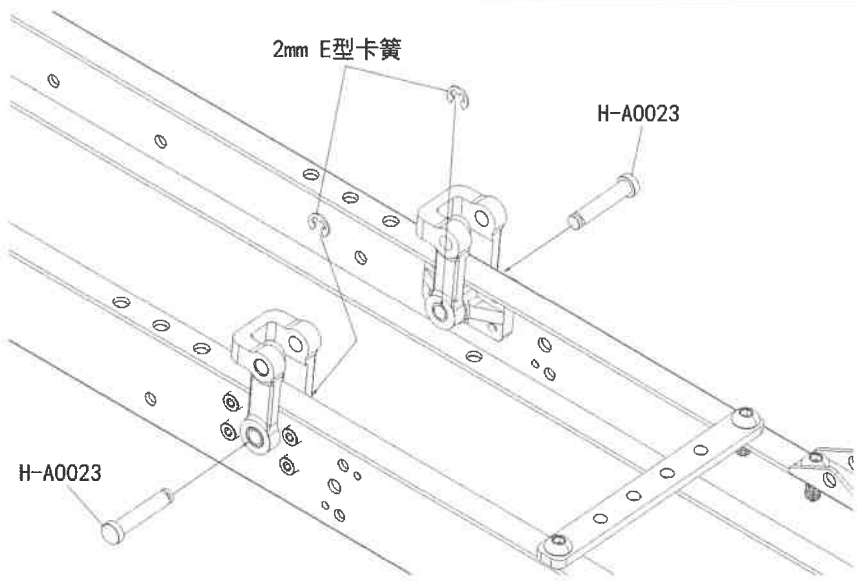

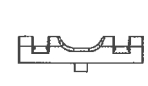

# 5 JXmodel

 MP-13  
x4

 MP-14  
x2

 MP-15  
x4

 MP-F1  
x2

 MP-F2  
x2

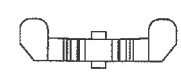
 MP-14  
x2

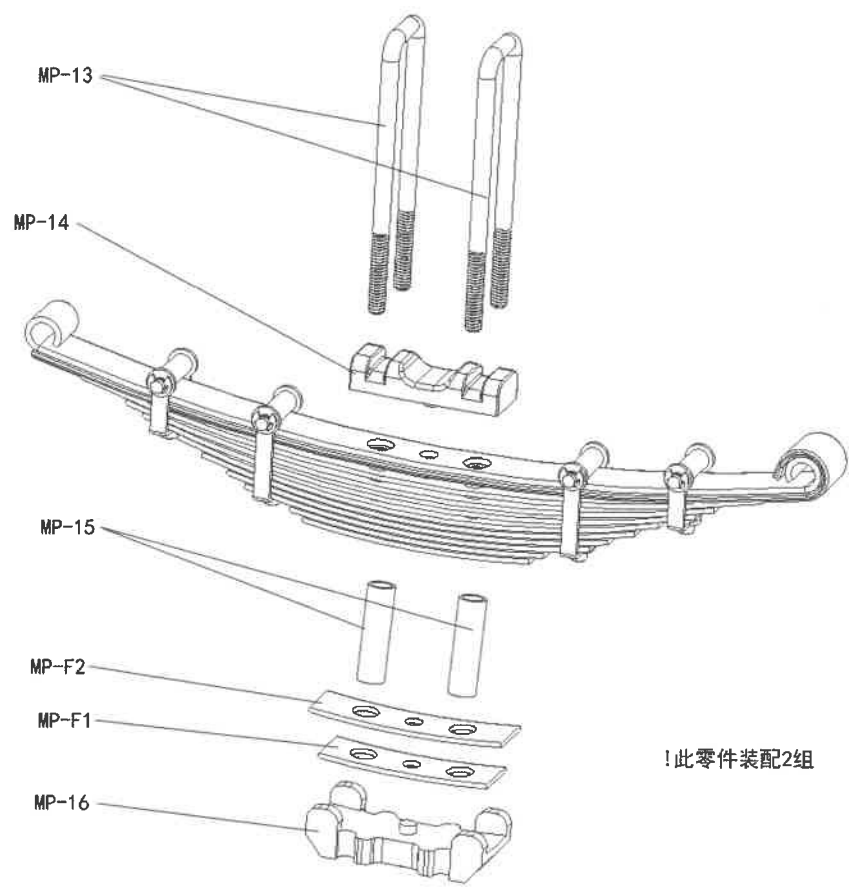

!此零件装配2组

# 6 JXmodel

 M2防松螺母  
x8

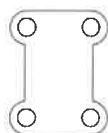
 MP-17  
x2

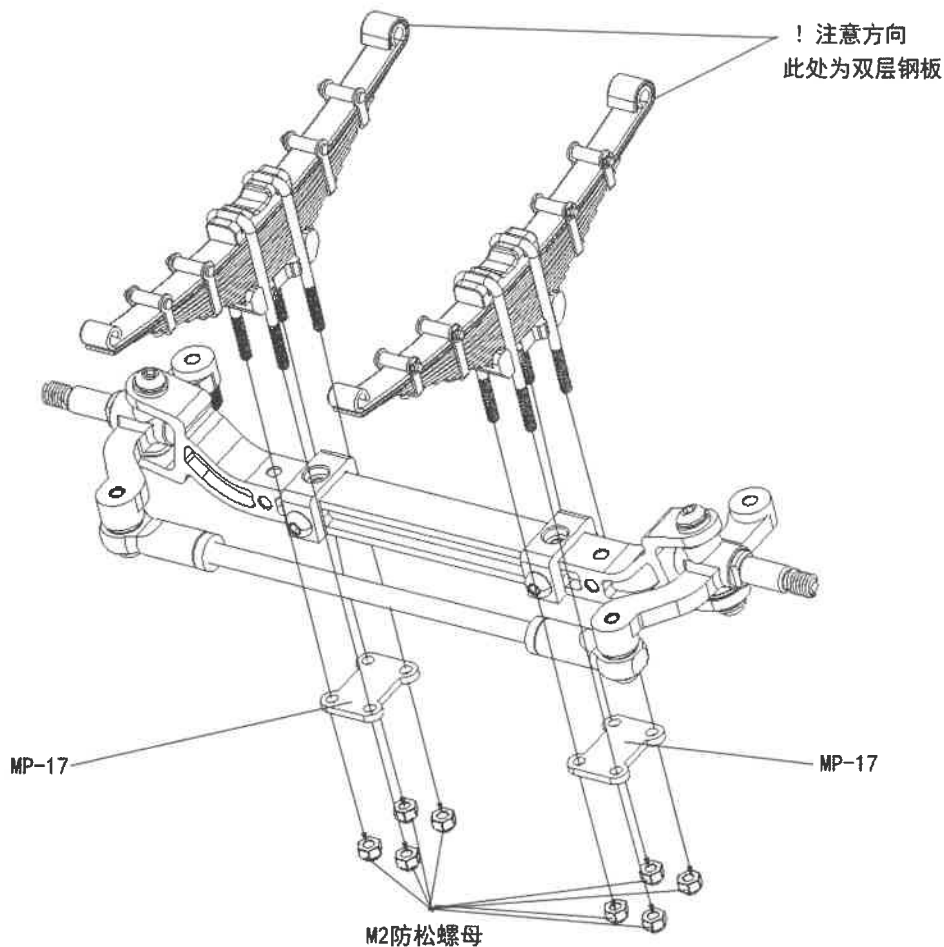

# 7 JXmodel

 2mm E型卡簧  
x2



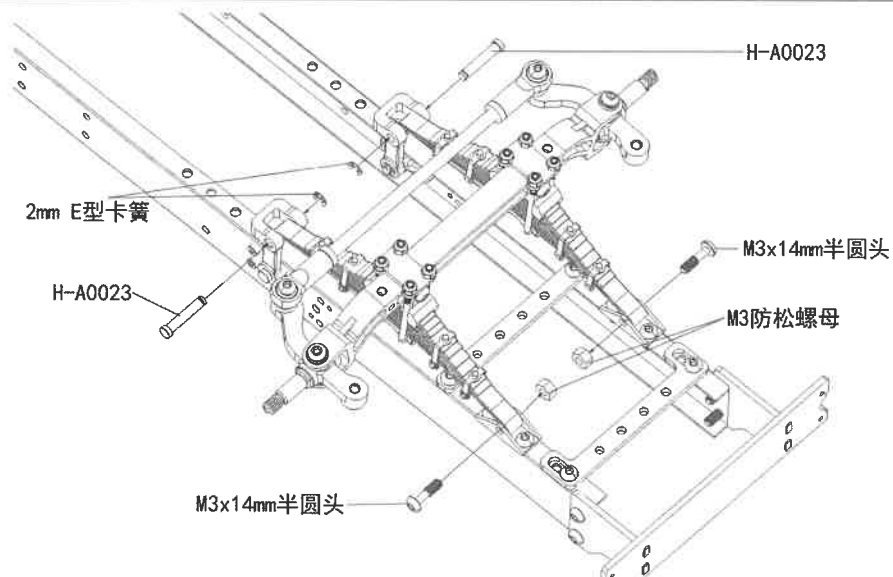

 M3x14mm半圆头  
x2

 M3防松螺母  
x2

 H-A0023  
x2



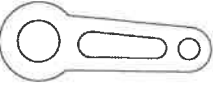

# 8 JXmodel

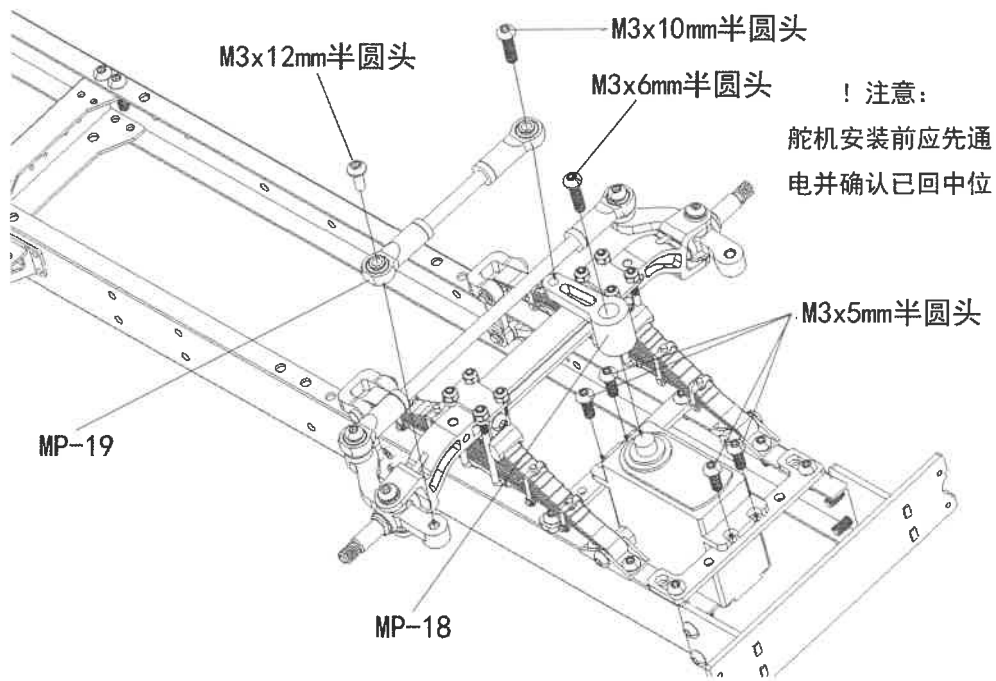
-  M3x5半圆头  
x4
-  M3x6半圆头  
x1
-  M3x10半圆头  
x1
-  M3x12半圆头  
x1
-  x1 MP-18

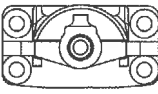

# 9 JXmodel

-  M2x6杯头  
x8
-  M2x6平头  
x16
-  x4 MP-20
-  x4 MP-21

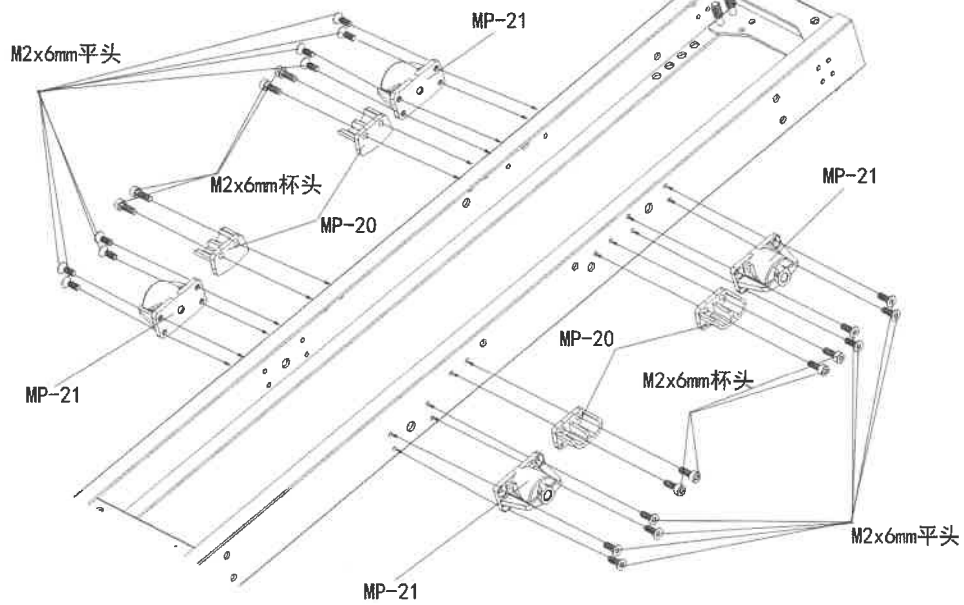

# 10 JXmodel

 2mm E型卡簧  
x2

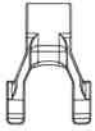

x2 MP-22

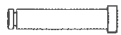

x2 H-A0022

!注意安装方向  
此处为双层钢板

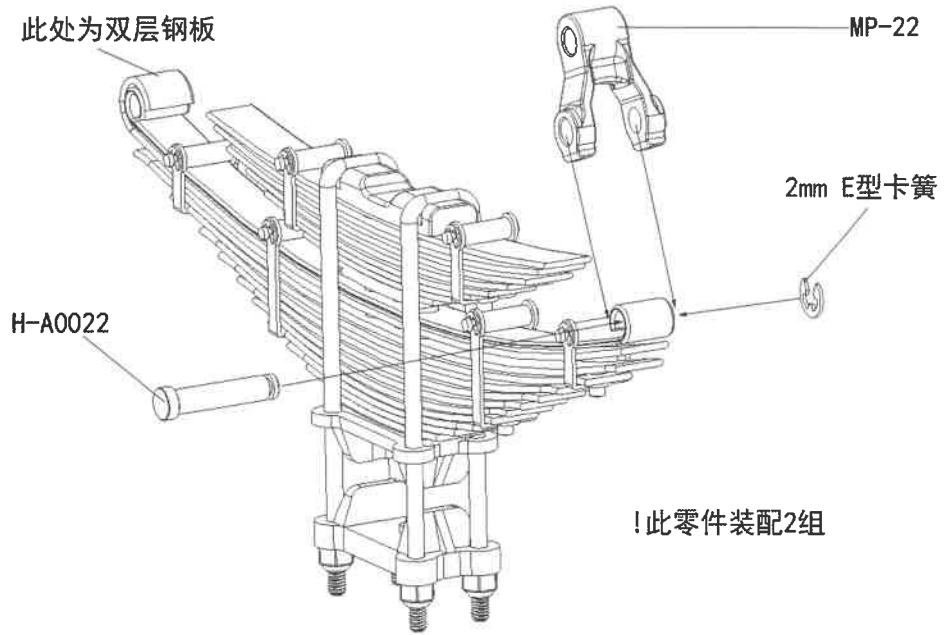

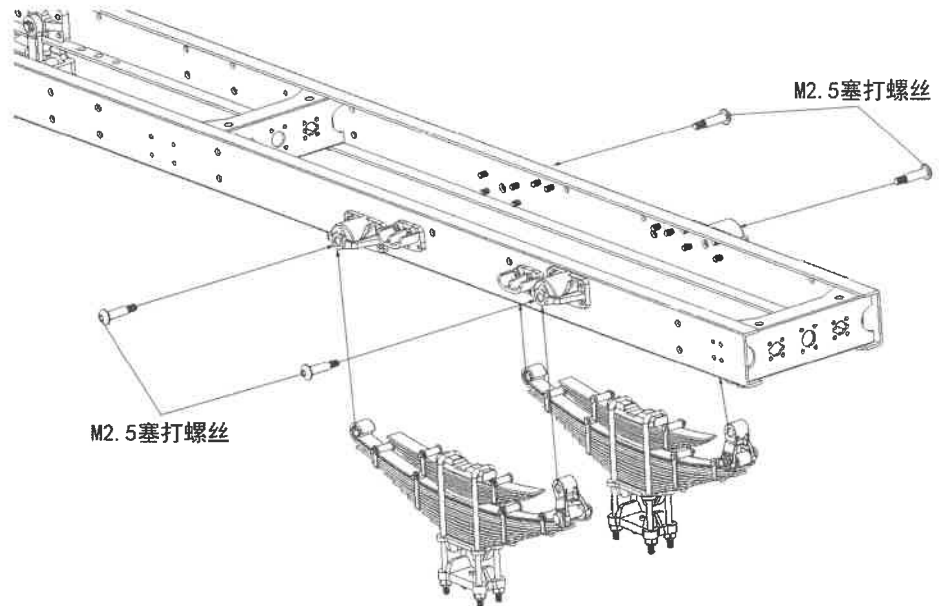

# 11 JXmodel

 M2.5塞打螺丝  
x4



## 12 JXmodel

 M2防松螺母  
x8

 x2 MP-23

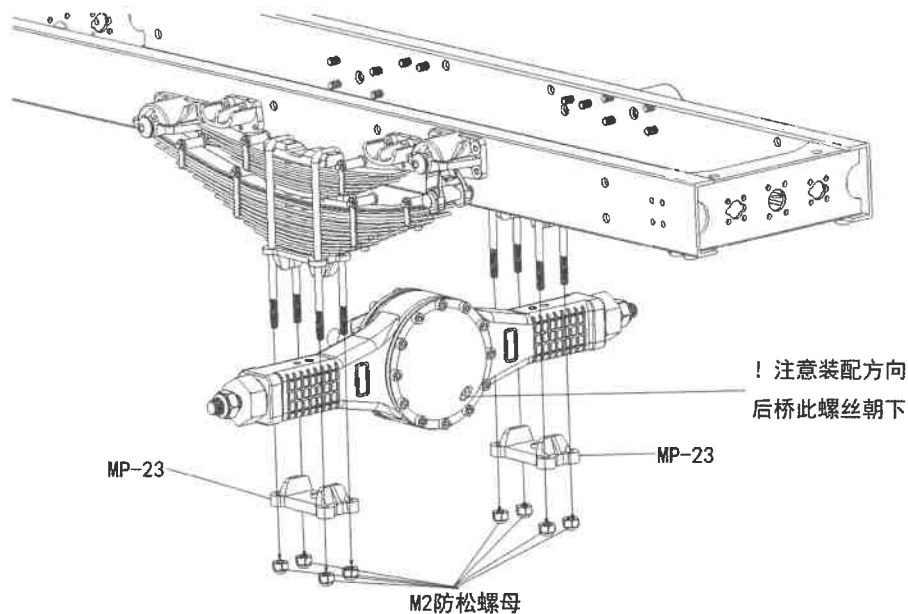

## 13 JXmodel

 x4 M3x27杯头

 x2 M3x6扁头十字

 起步齿轮

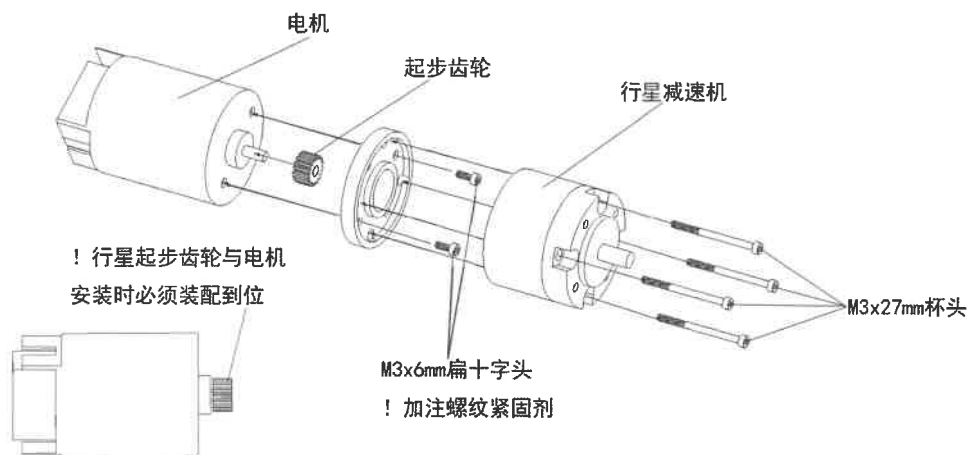

## 14 JXmodel

 M3x5半圆头  
x4

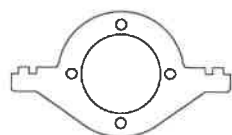
 x1 MP-24

! 加注螺纹紧固剂  
M3x5mm半圆头

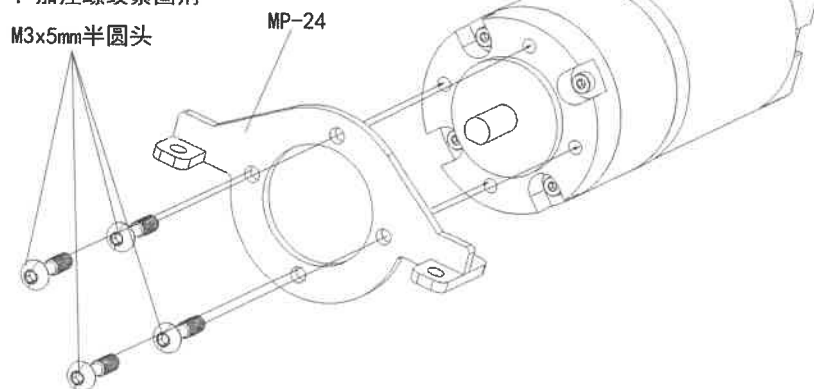



# 15 JXmodel

M3x8半圆头  
x4

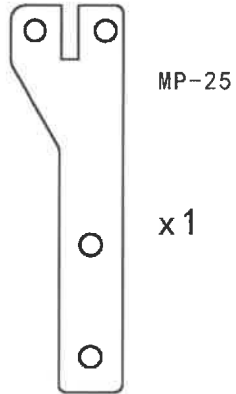

M3x8mm半圆头  
! 加注螺纹紧固剂

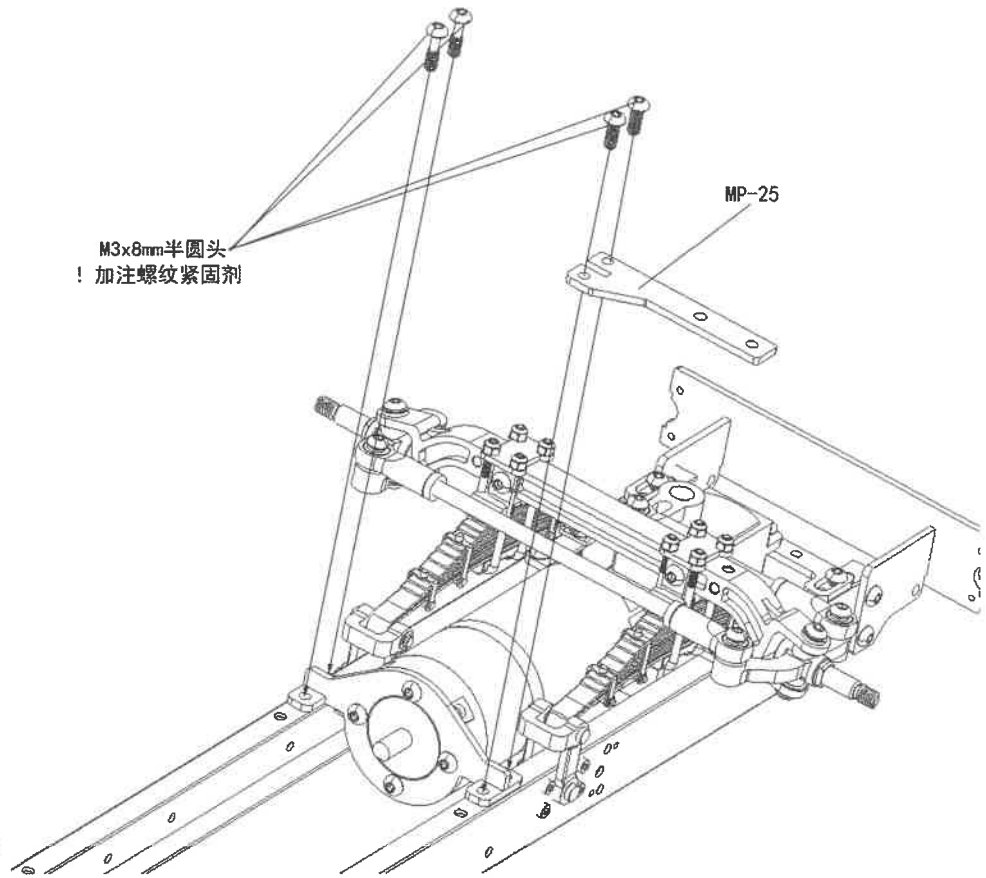

# 16 JXmodel

M2x5半圆头  
x4

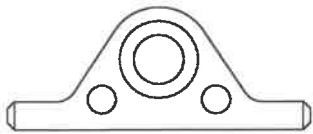

MP-26

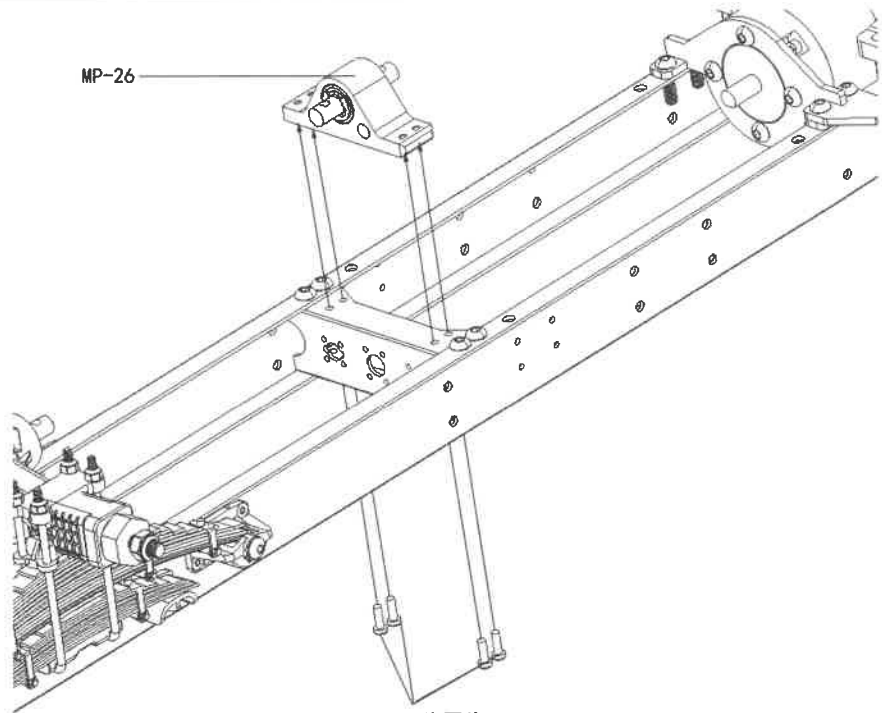

# 17 JXmodel

M3x4机米螺丝  
x4

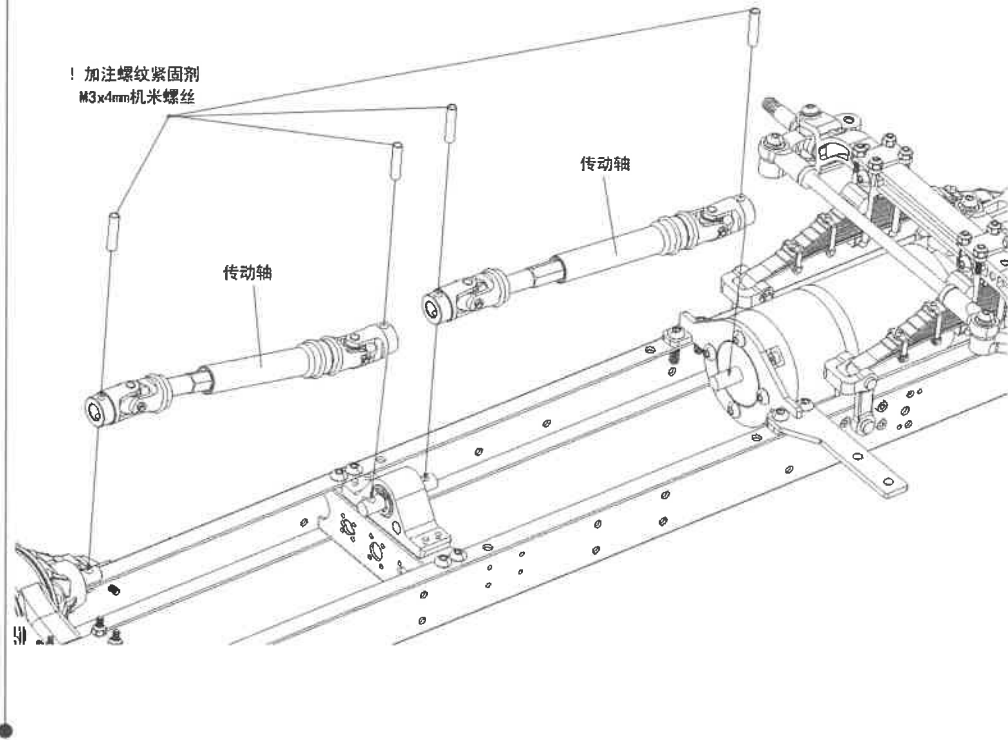

# 18 JXmodel

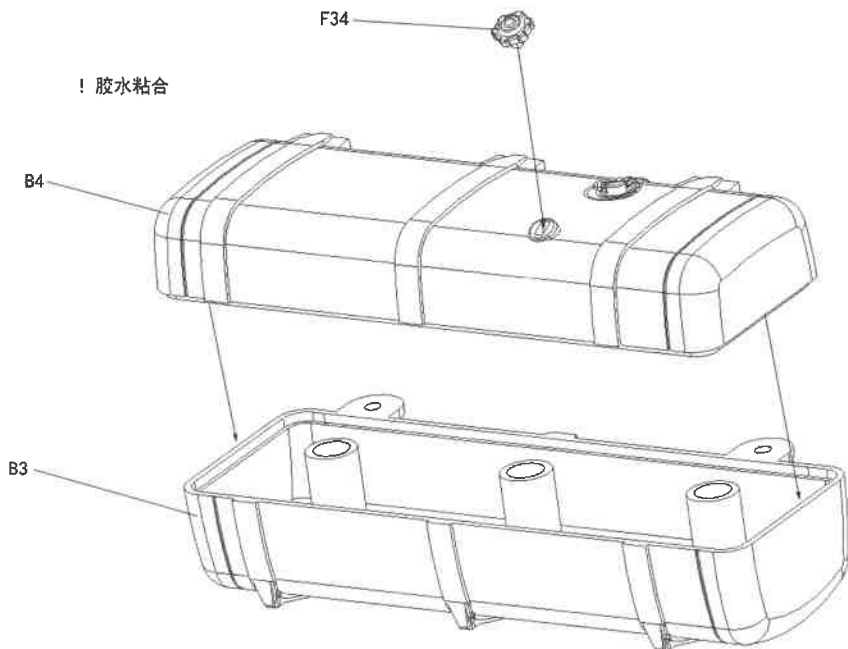

# 19 JXmodel

M3x9mm半圆头

 M3x9mm半圆头  
x2

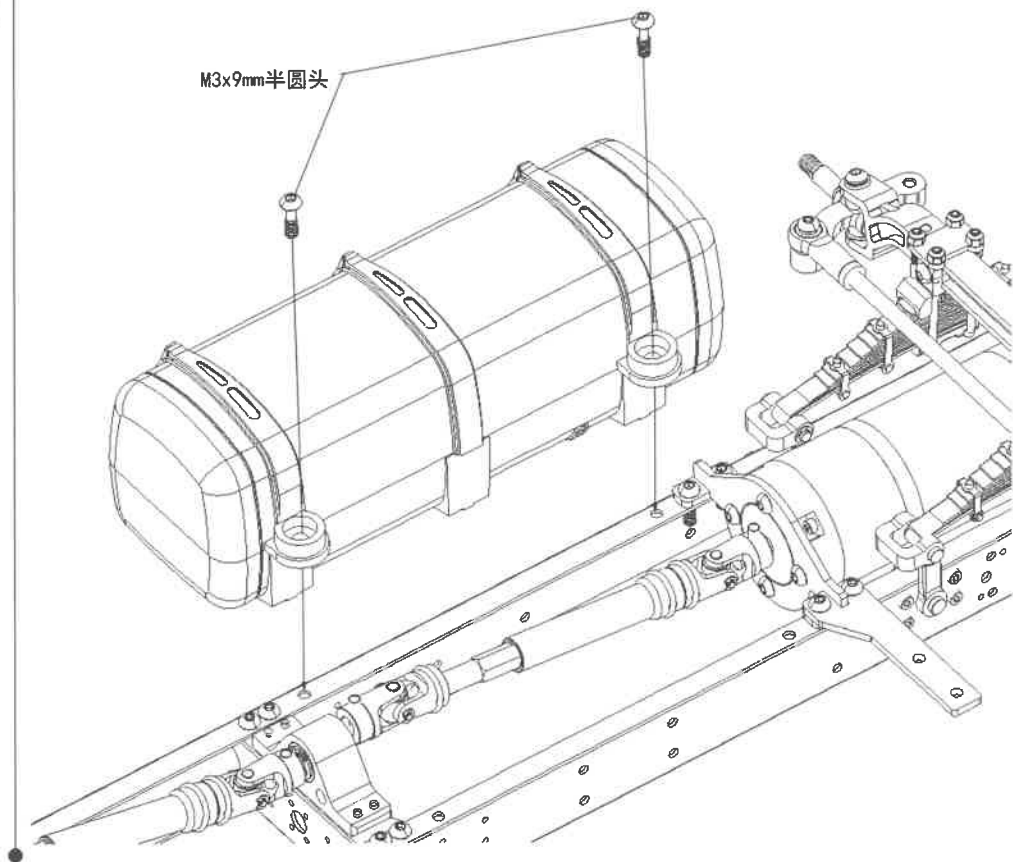

# 20 JXmodel

M3x4mm扁十字头

 M3x4mm扁十字头  
x2

 x1 MP-27

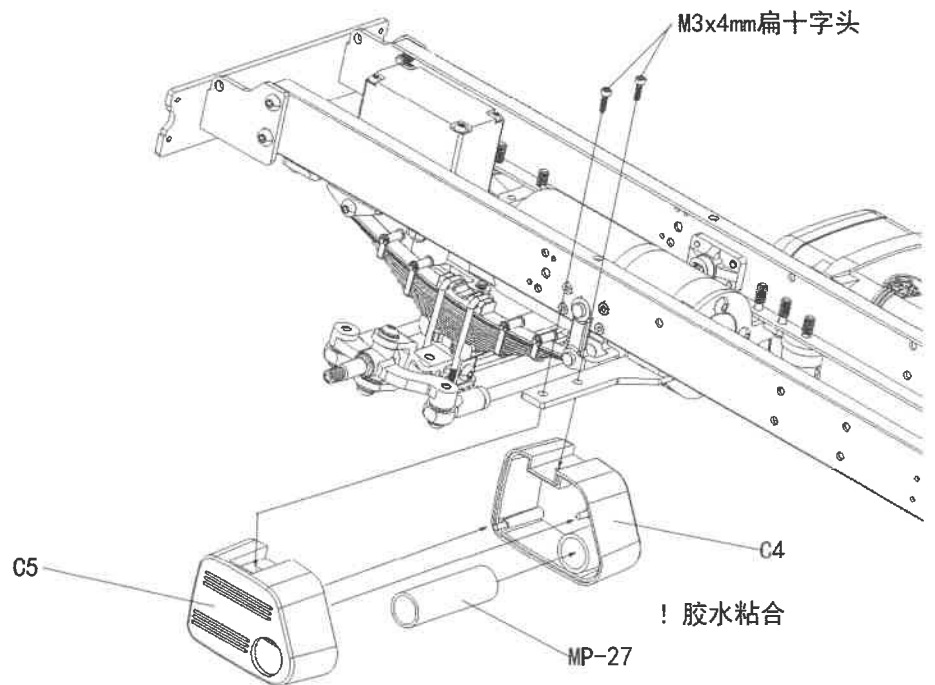

## 21 JXmodel

M3x4扁十字头  
x8

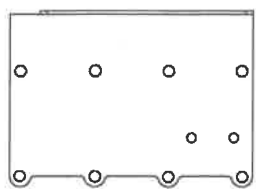

x1 MP-28

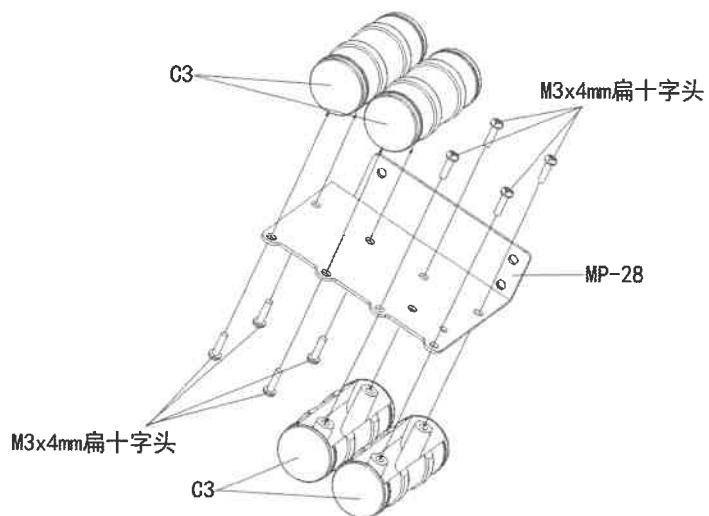

## 22 JXmodel

M3x6半圆头  
x3

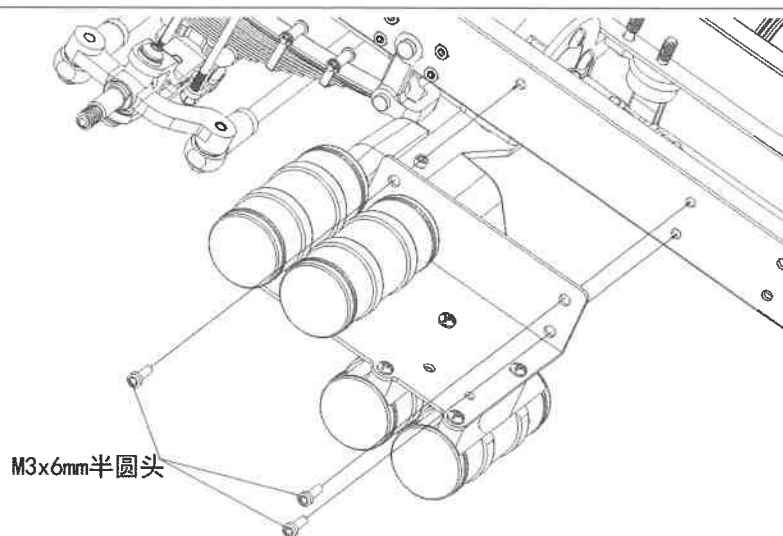

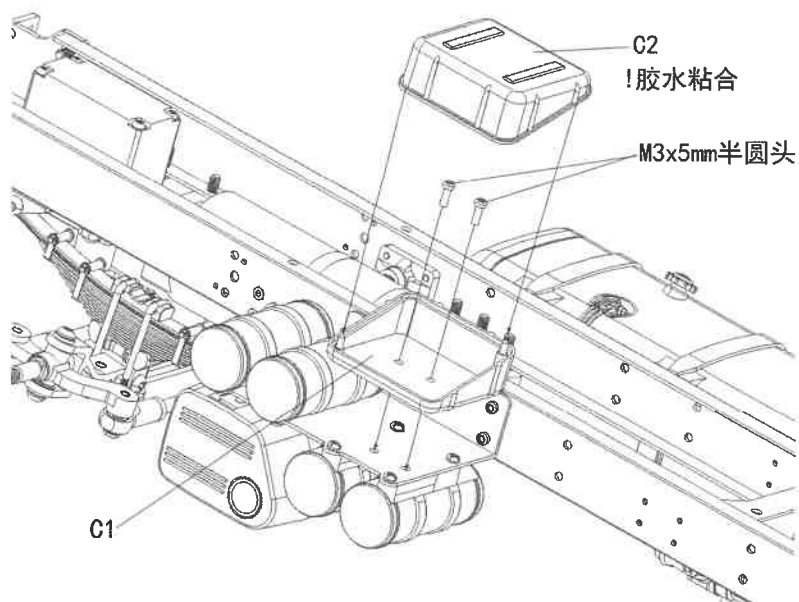

## 23 JXmodel

M3x5半圆头  
x2



# 24 JXmodel

-  M2x5半圆头  
x3
-  M2螺母  
x3

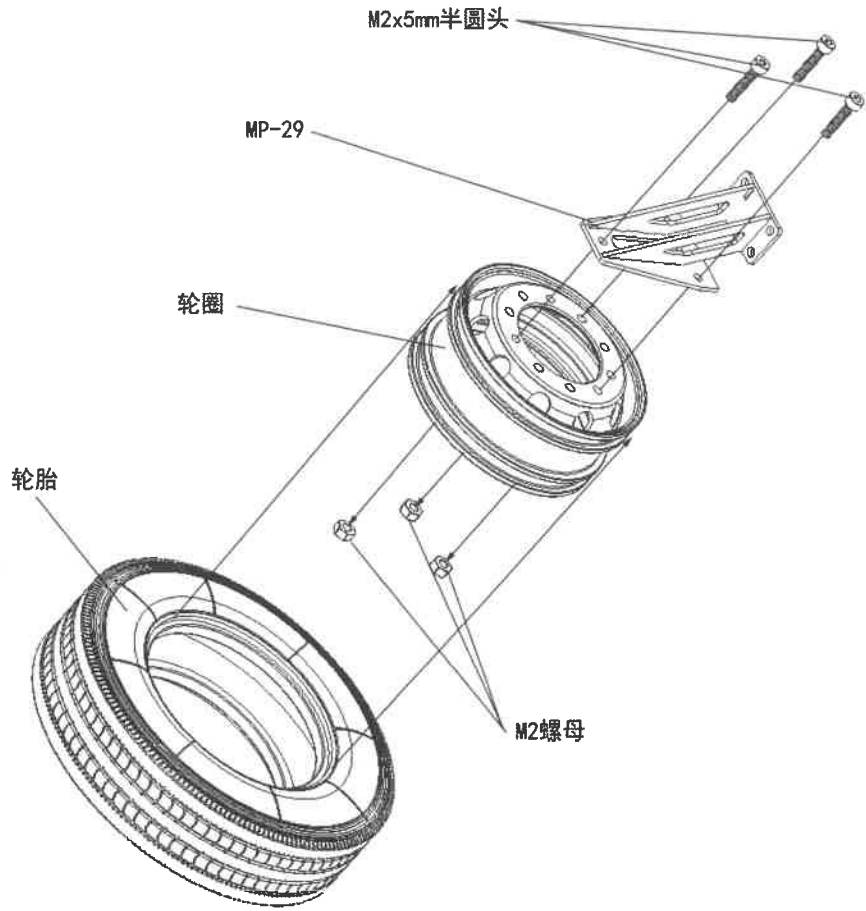
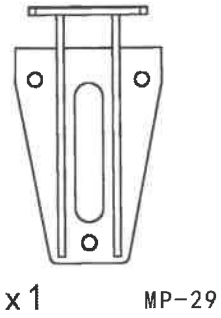

# 25 JXmodel

-  M2x5半圆头  
x4

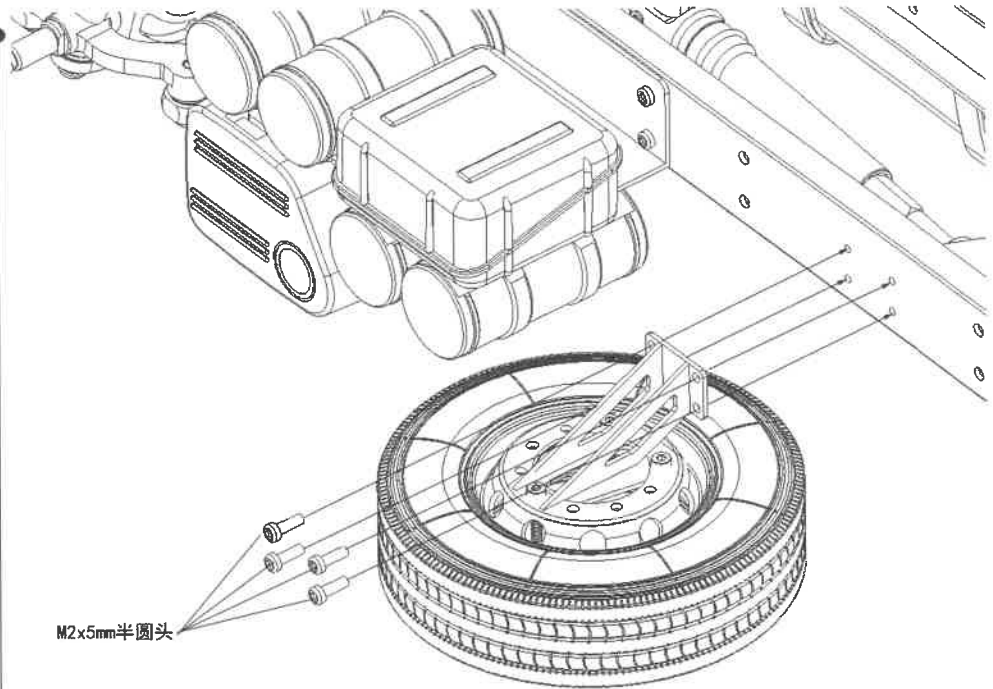

## 26 JXmodel

M2x5半圆头  
x4

M2x8半圆头  
x8

M2螺母  
x4

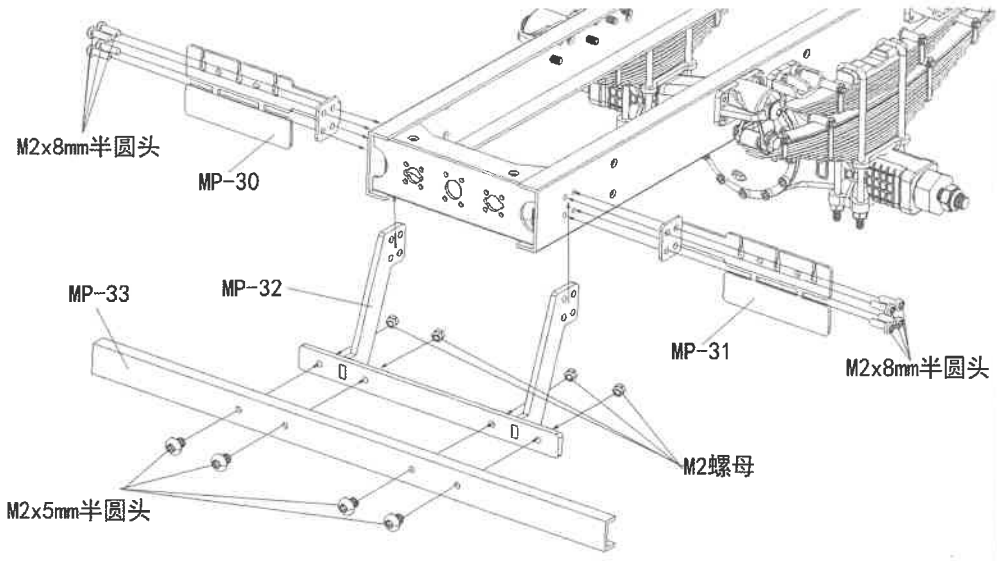
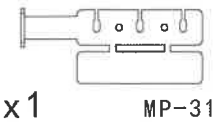
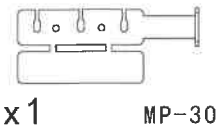

## 27 JXmodel

! 建议涂装颜色  
透明黄 透明红 透明

! 胶水粘合

M2x5半圆头  
x4

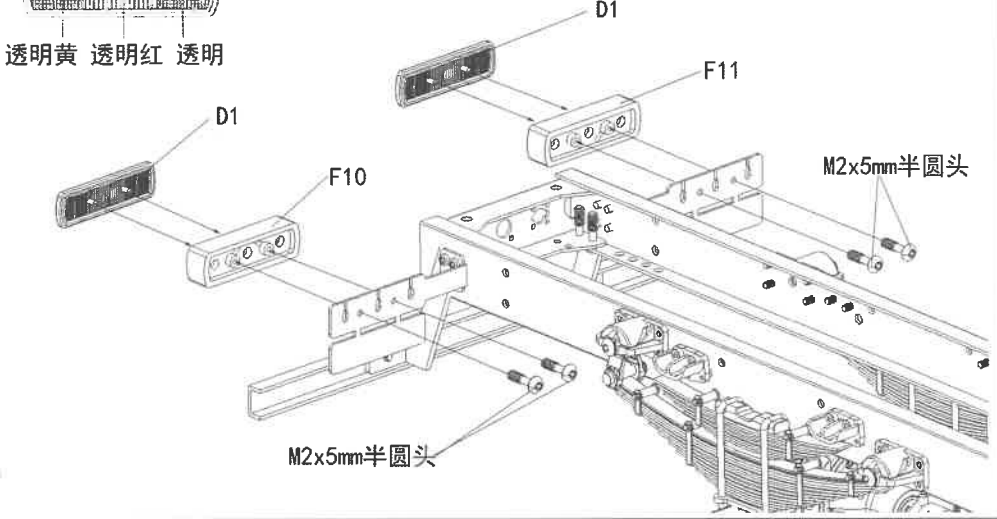

## 28 JXmodel

M2x5半圆头  
x4

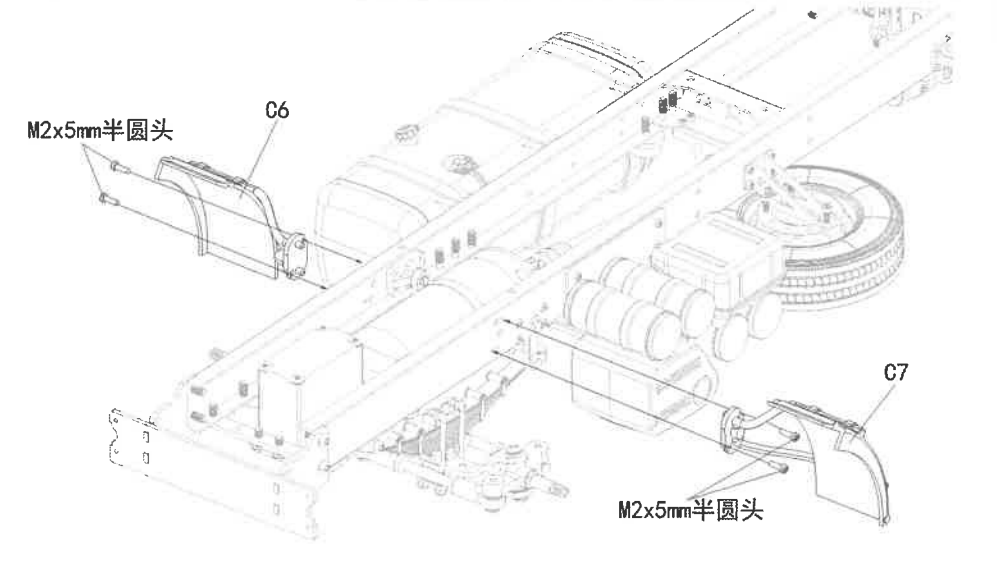

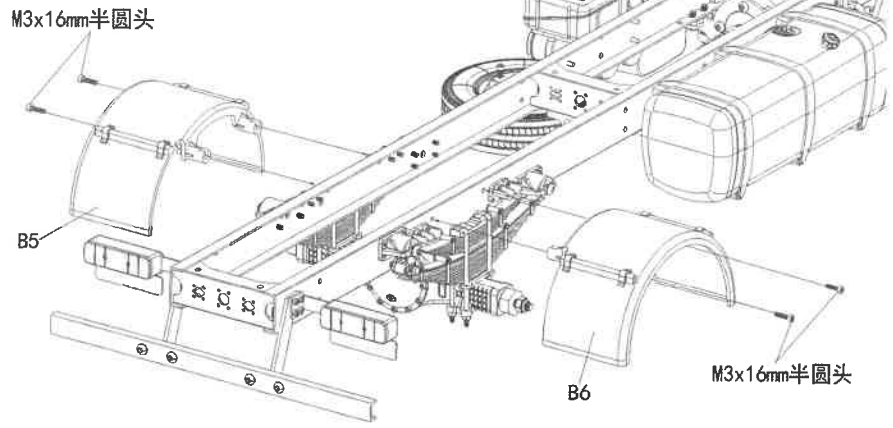

# 29 JXmodel

-  M3x16半圆头
- x4



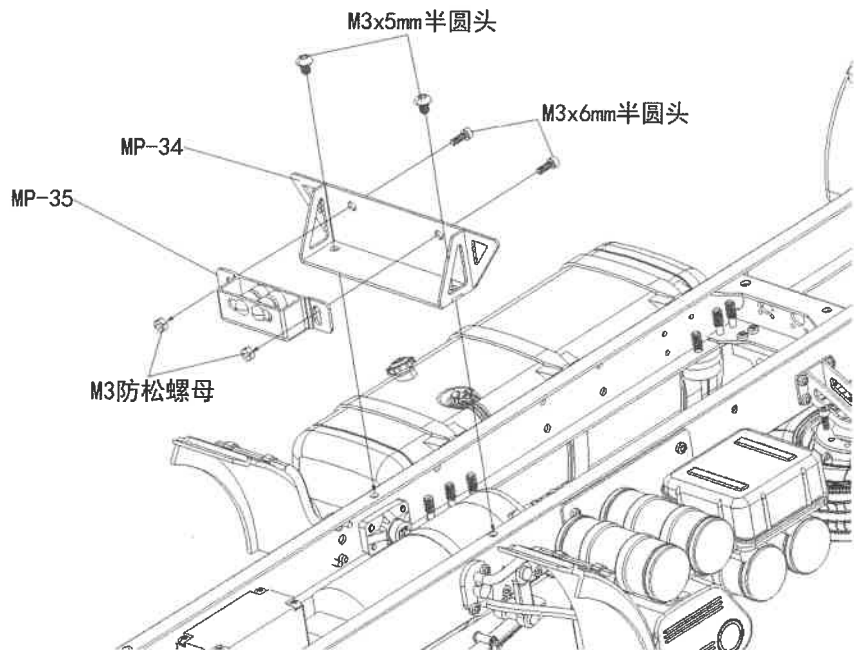
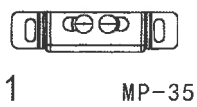
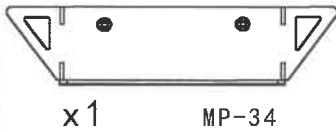

# 30 JXmodel

-  M3x5半圆头
- x2
-  M3x6半圆头
- x2
-  M3防松螺母
- x2



# 31 JXmodel

-  M2x10杯头
- x20
-  M2螺母
- x20

! 后轮组件装配示意图

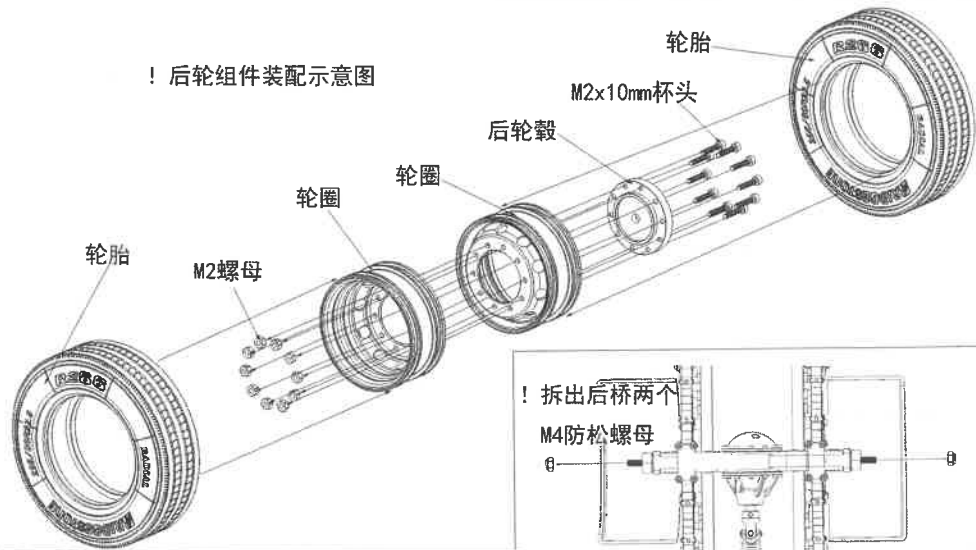

### 32 JXmodel

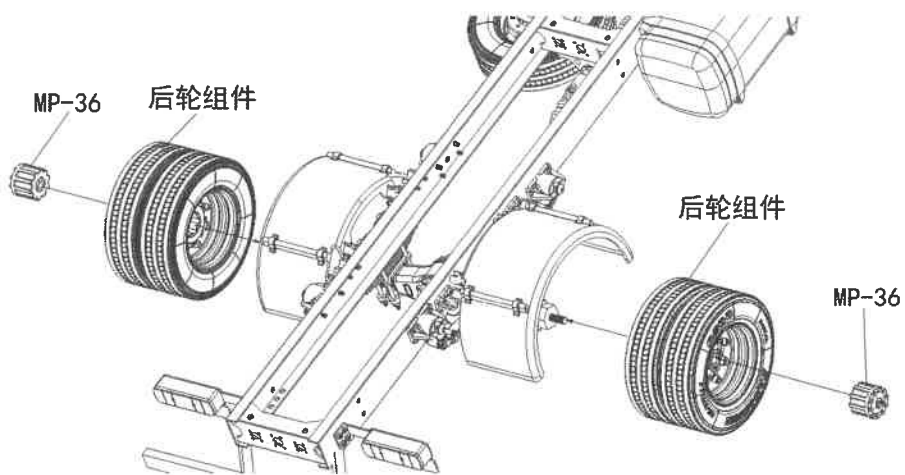
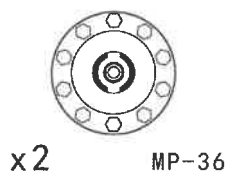

### 33 JXmodel

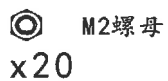
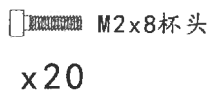

! 前轮组件装配示意图

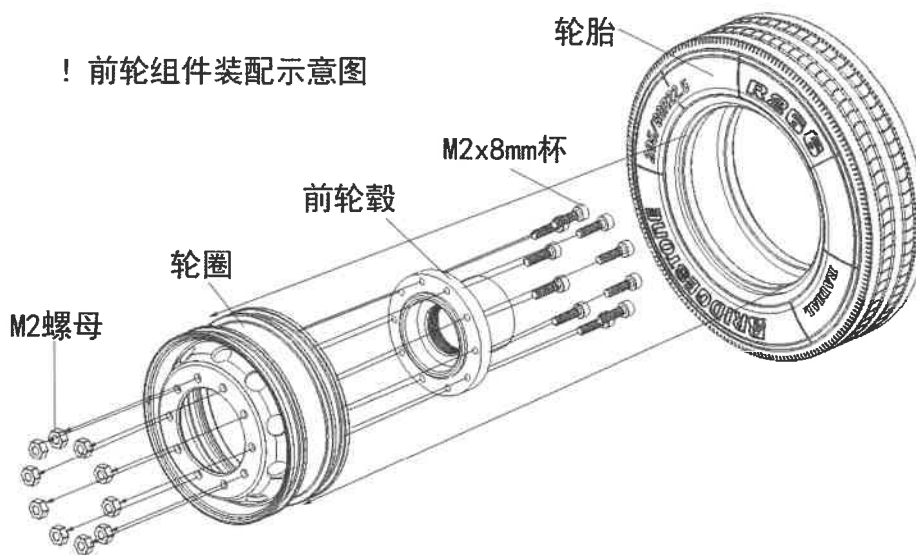

### 34 JXmodel

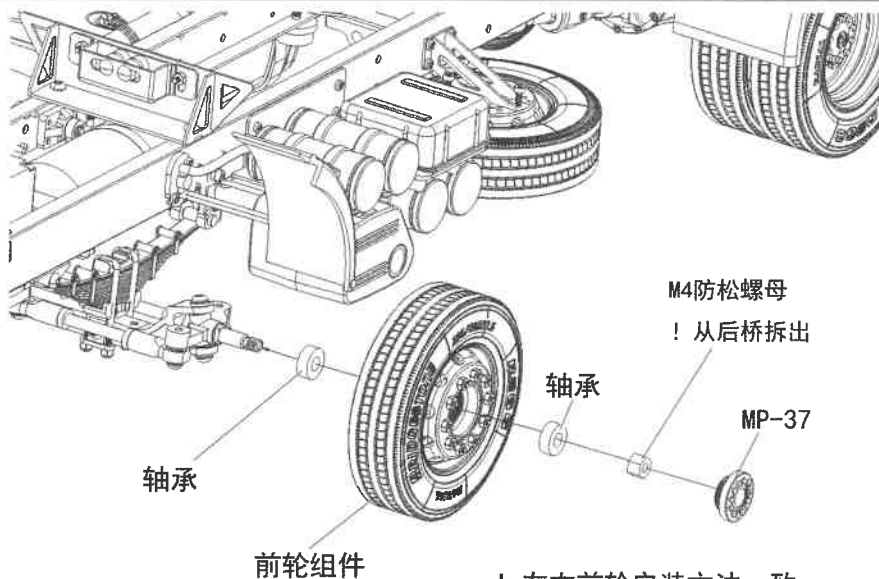
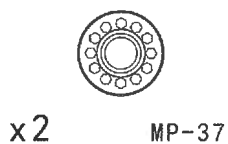



# 35 JXmodel

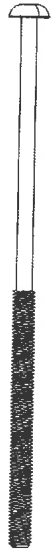

MP-38  
M3x75十字  
x1



M3防松螺母  
x1

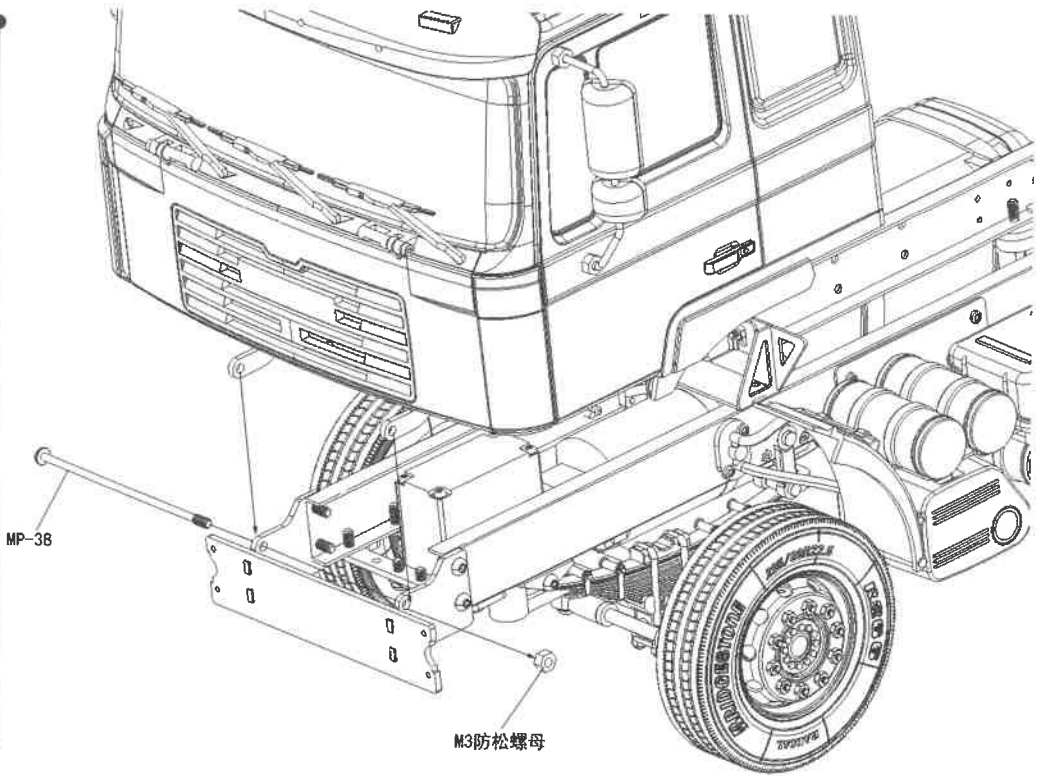

# 36 JXmodel



M2x10平头  
x4

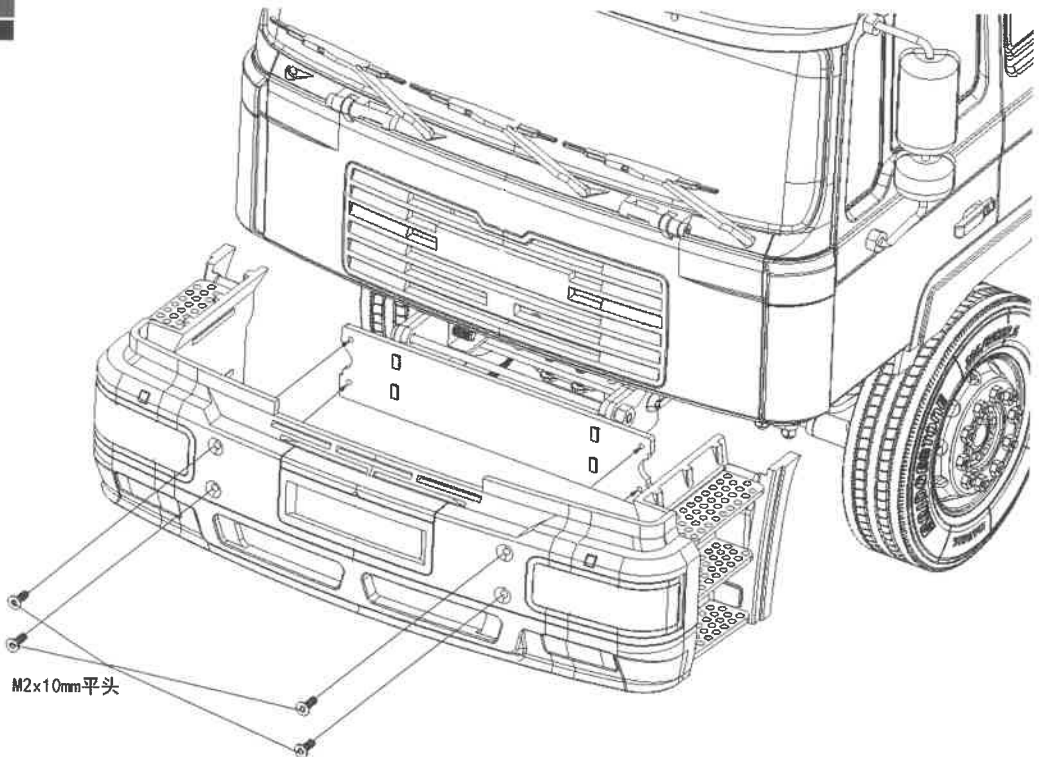

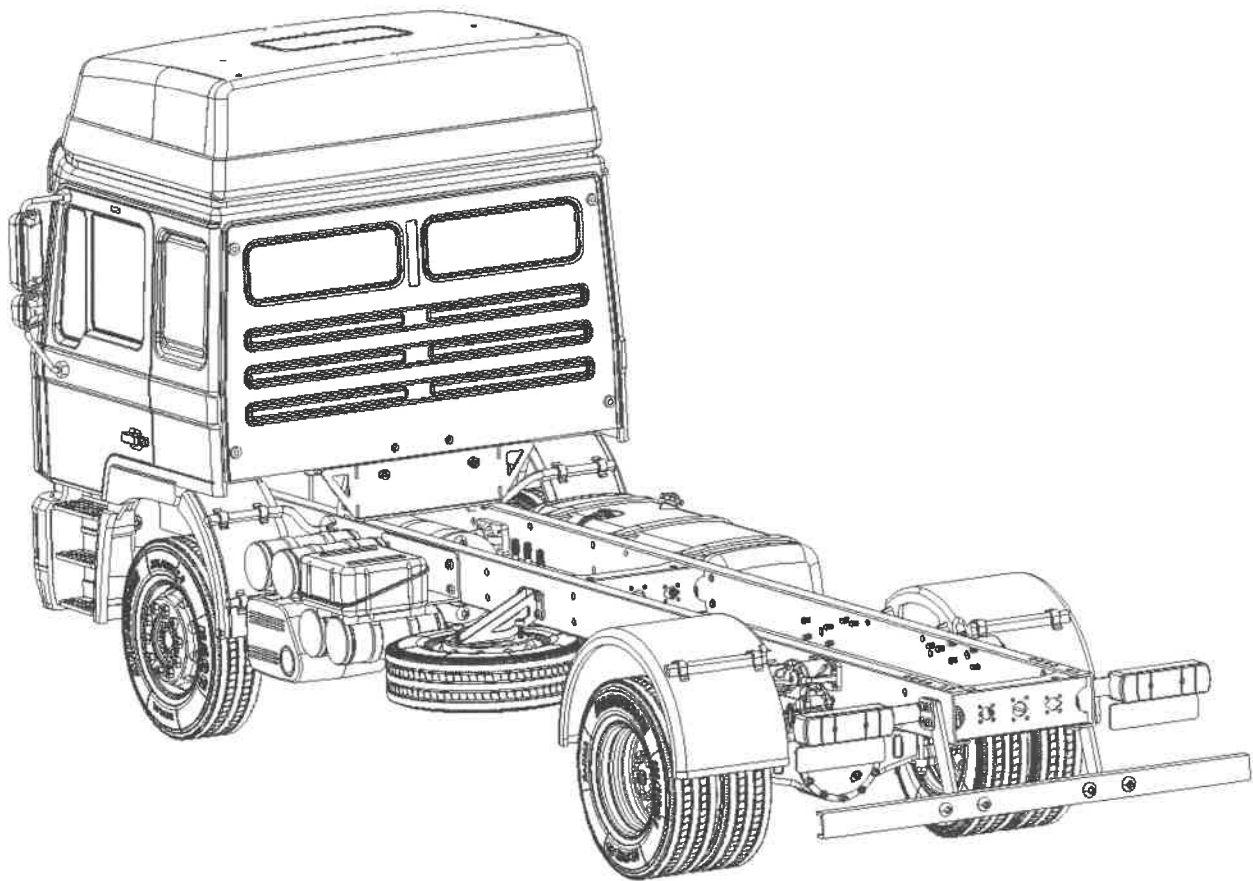
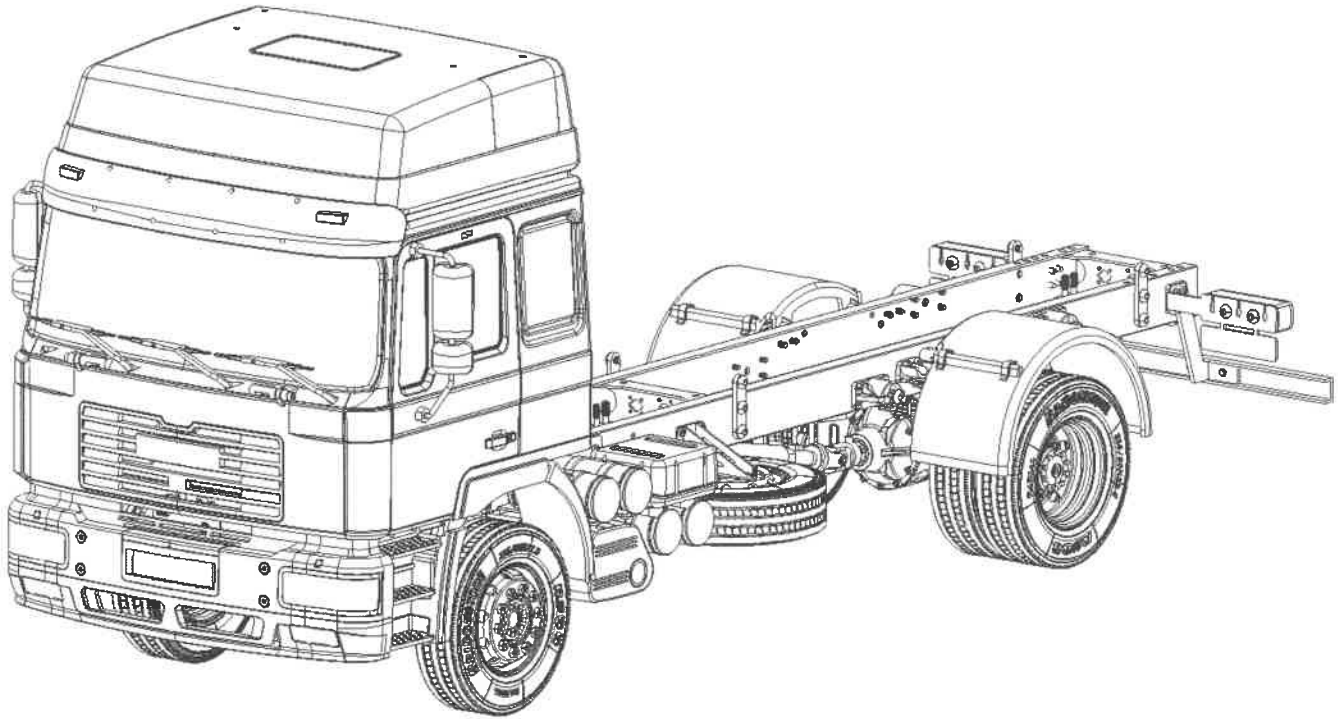

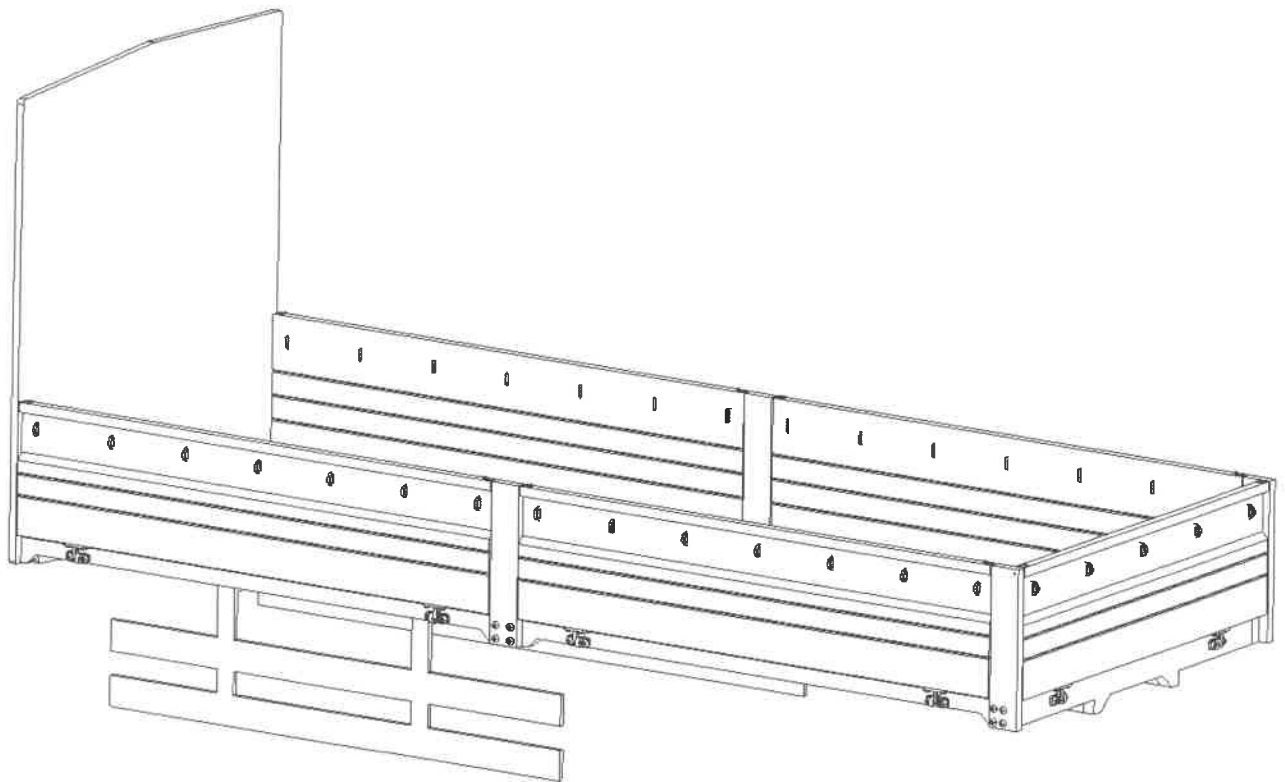
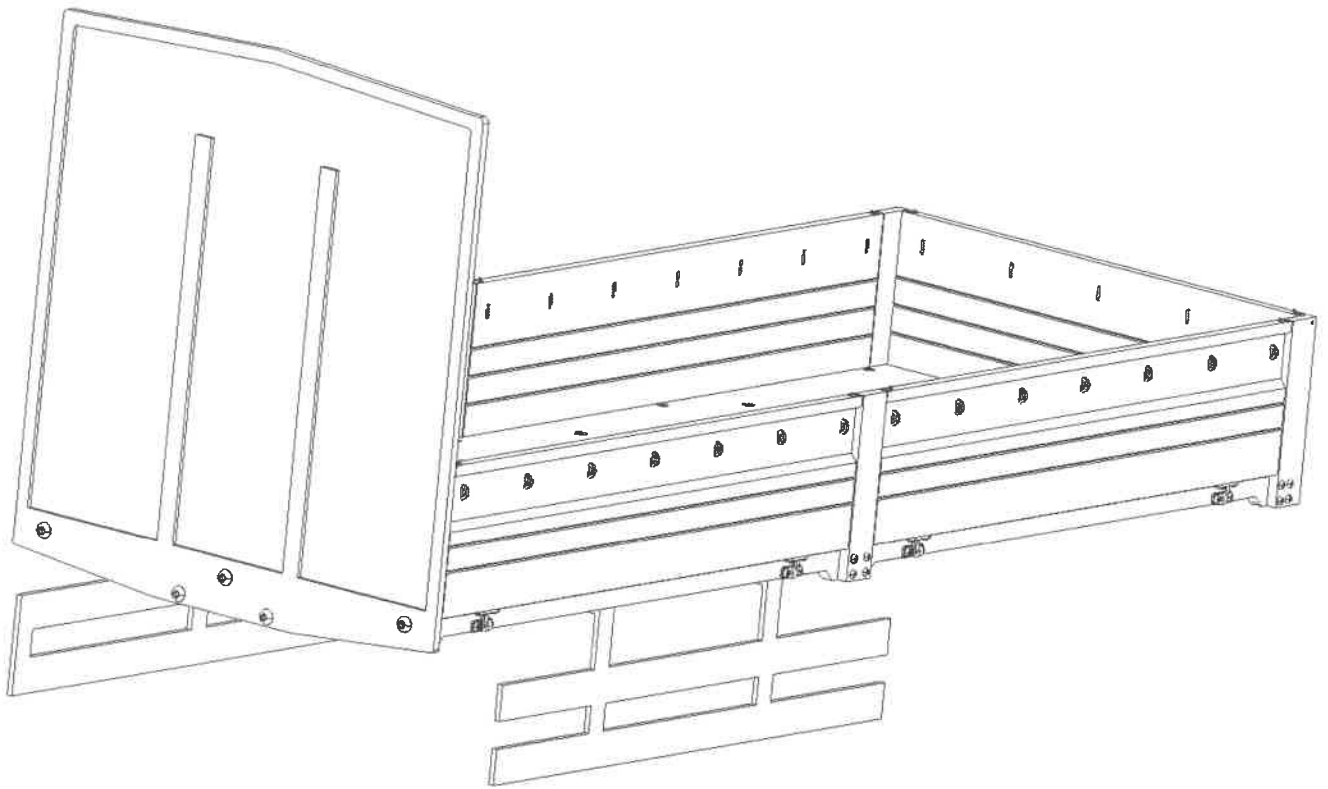

# 1 JXmodel



x12

M2x4平头内六角

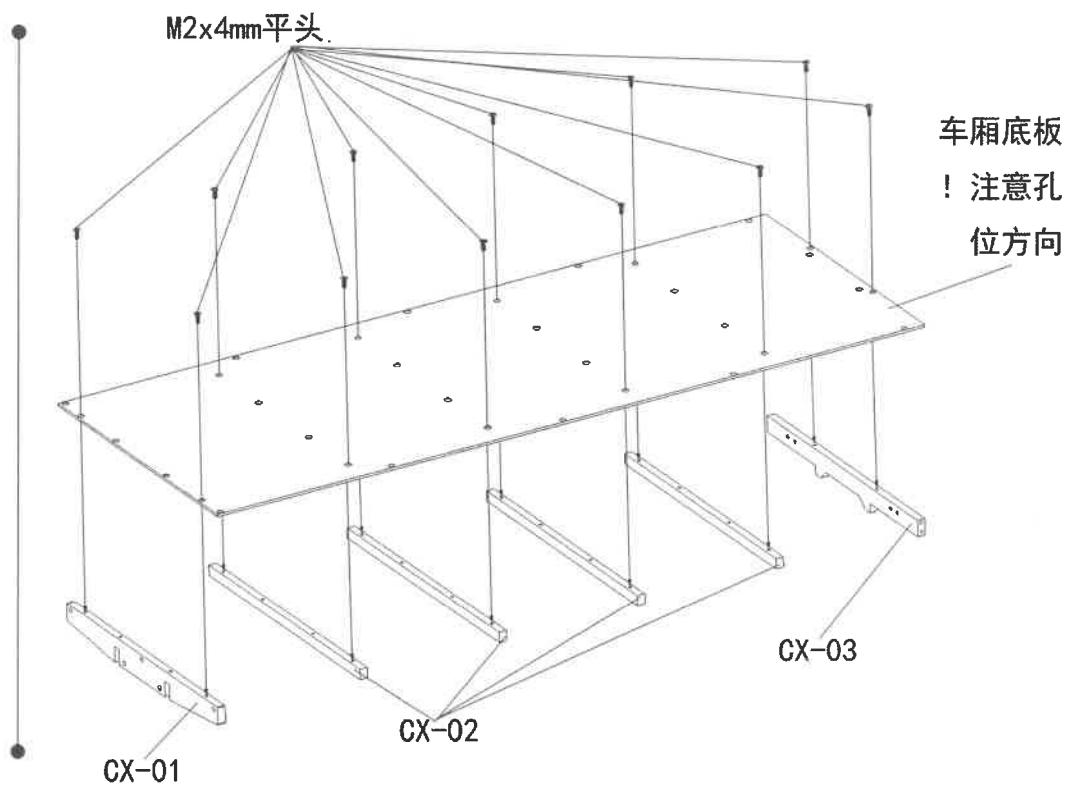

# 2 JXmodel

! 注意孔位方向

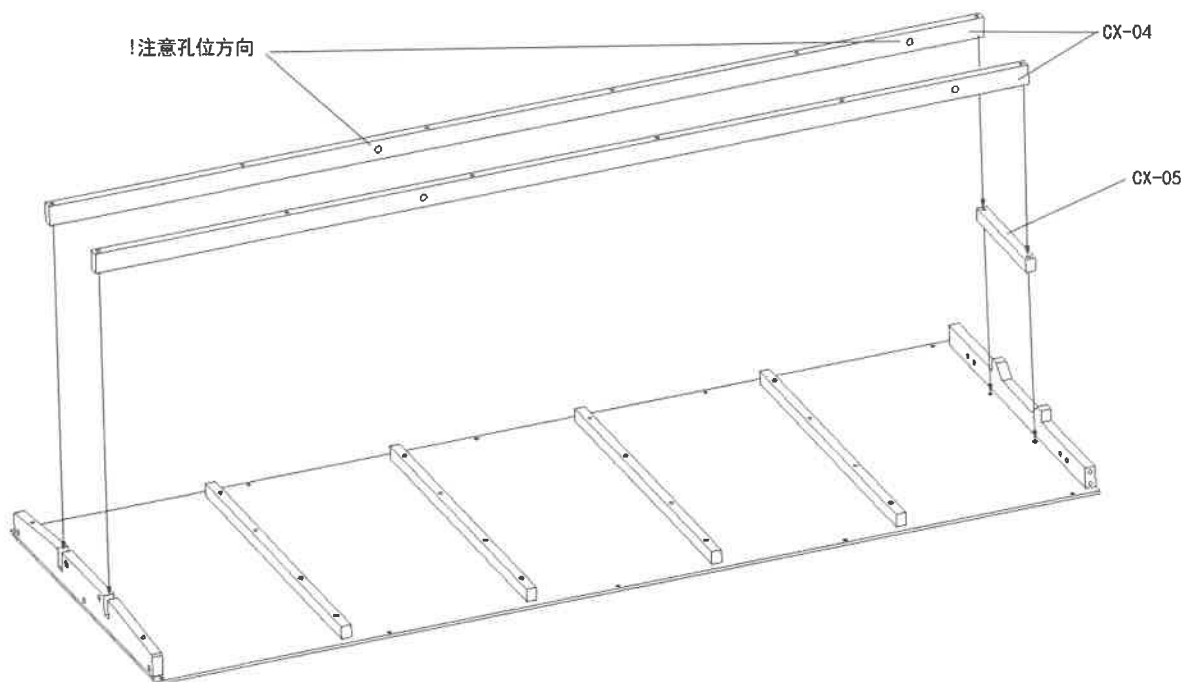

### 3 JXmodel

—  
x12

M2x12平头内六角

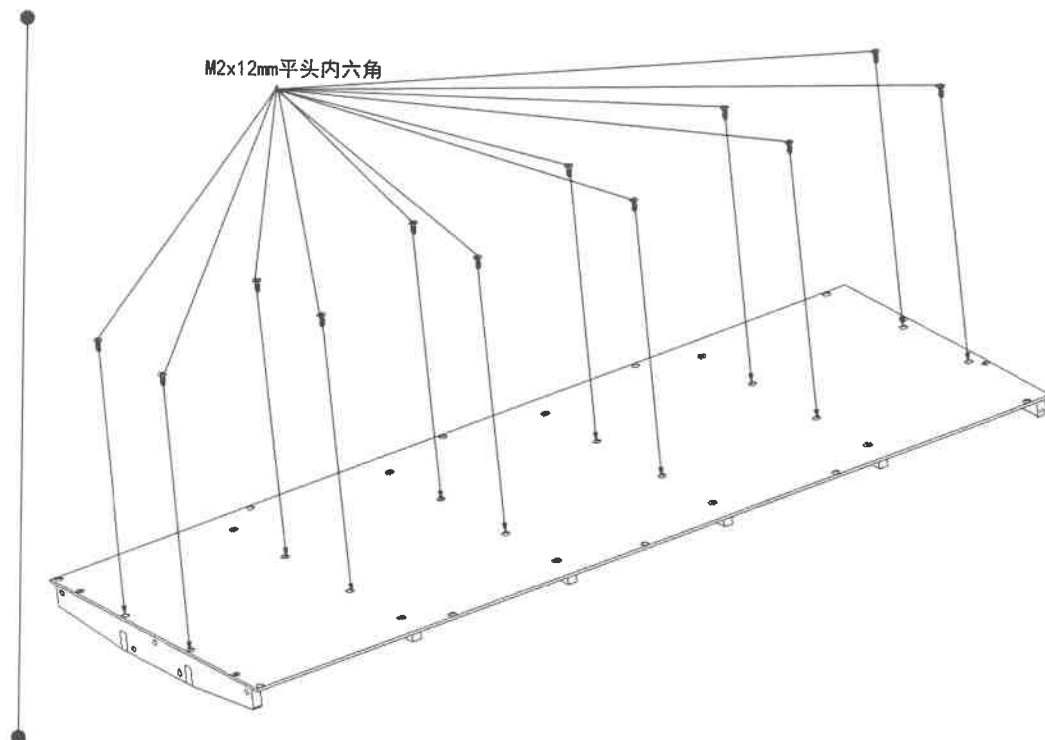

### 4 JXmodel

—  
x10

M2x4平头内六角

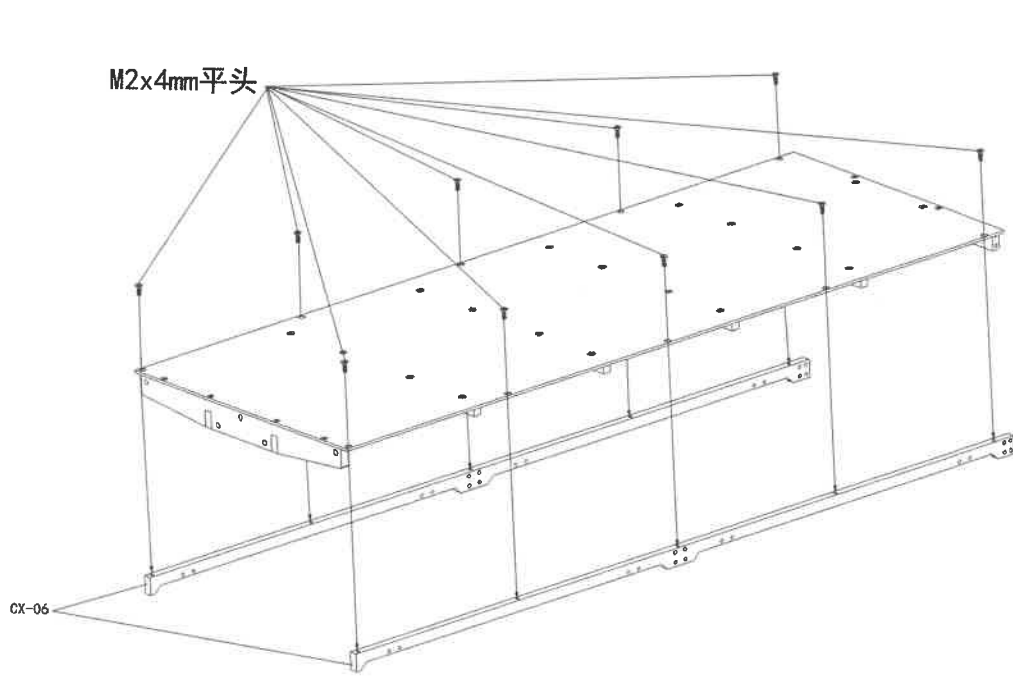

# 5 JXmodel



x5  
M3x12 半圆头内六角



M3防松螺母  
x5

M3x12mm半圆头

CX-07

M3防松螺母

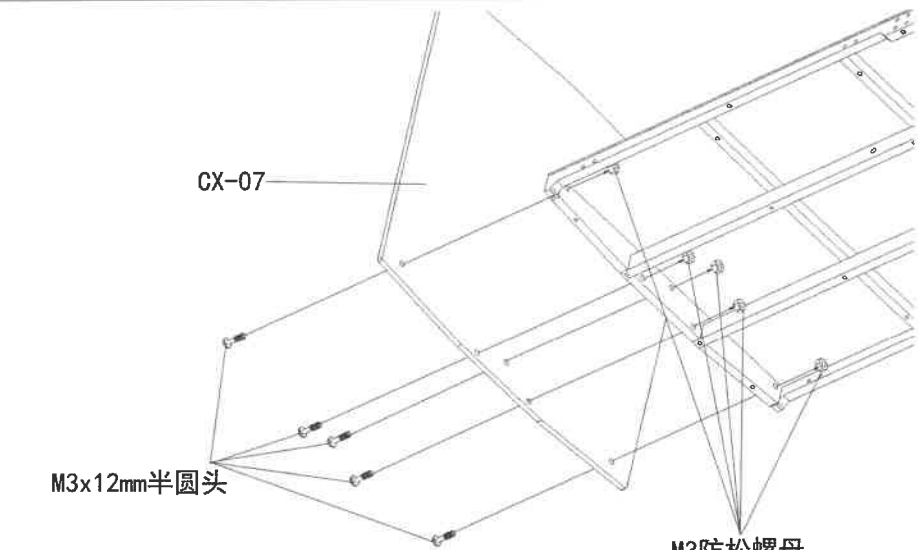

# 6 JXmodel

M2x12外六角

x16

M2螺母

x14



x2 CX-08



x1 CX-09



x1 CX-10

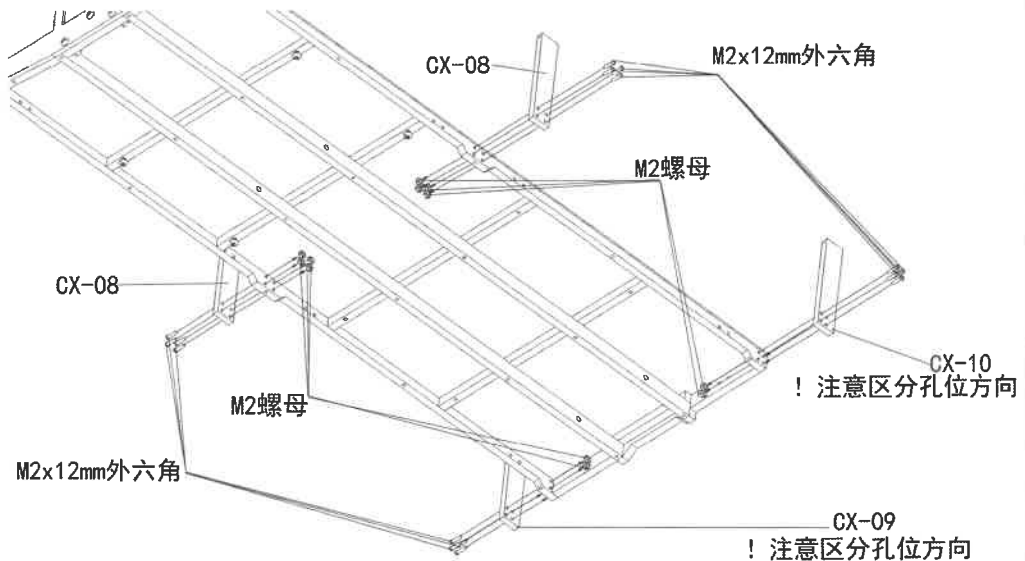

# 7 JXmodel

CX-11

x33

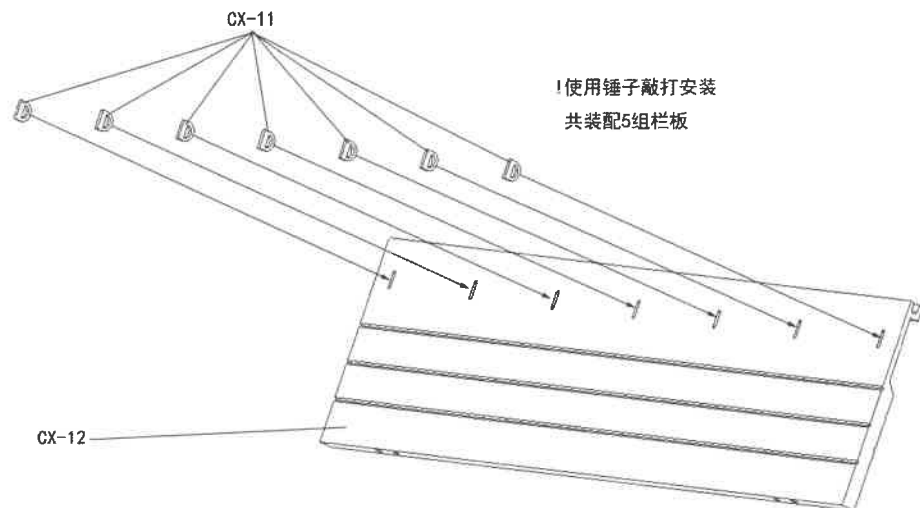

M2x4十字头  
x20

CX-13  
x10

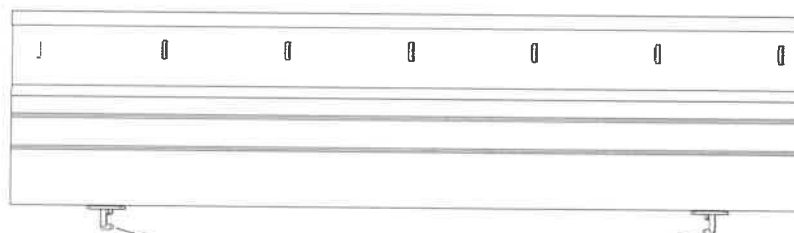
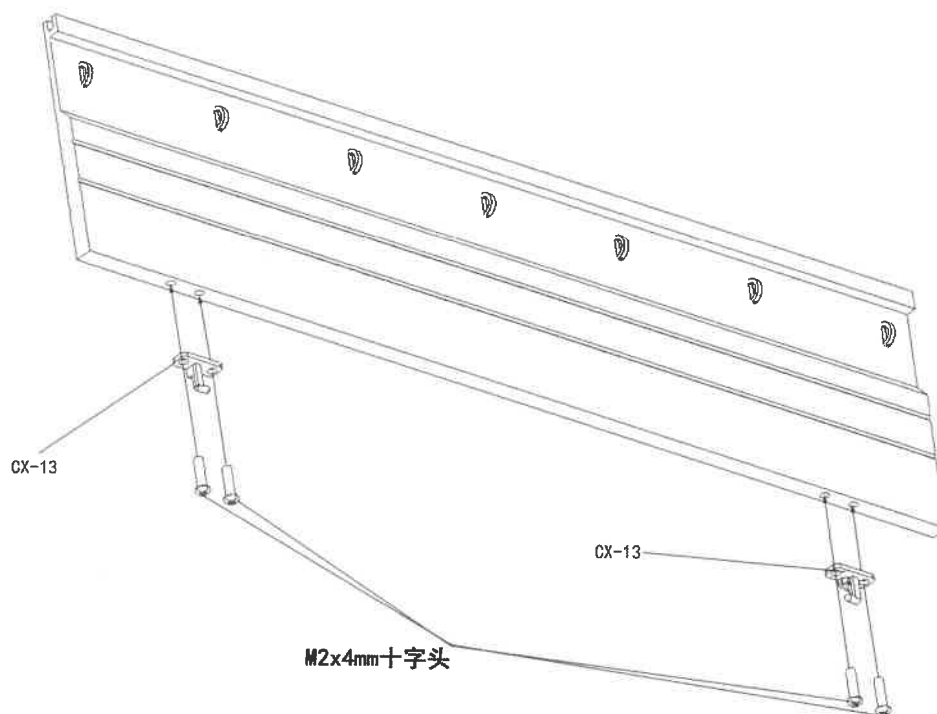

!注意合页装配方向  
对称装配  
共装配5组栏板

CX-14  
x10

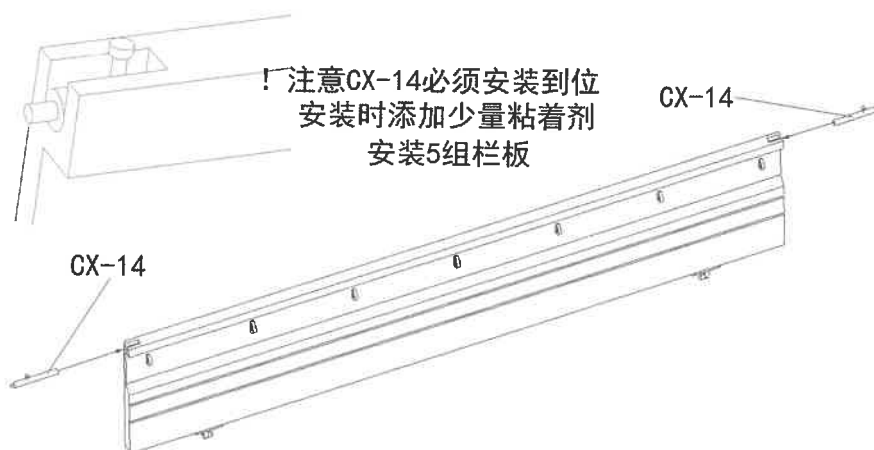

# 10 JXmodel

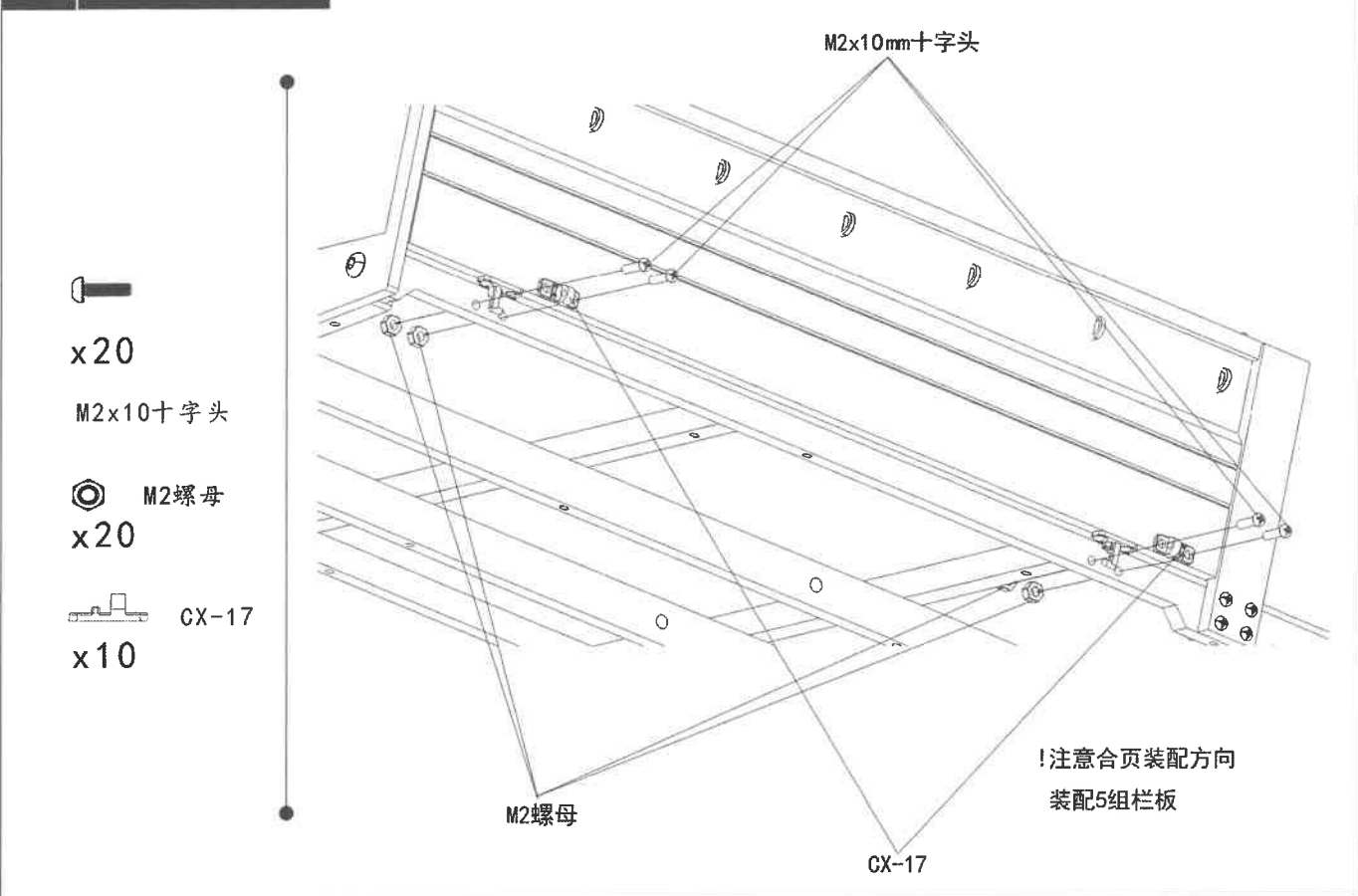

# 11 JXmodel

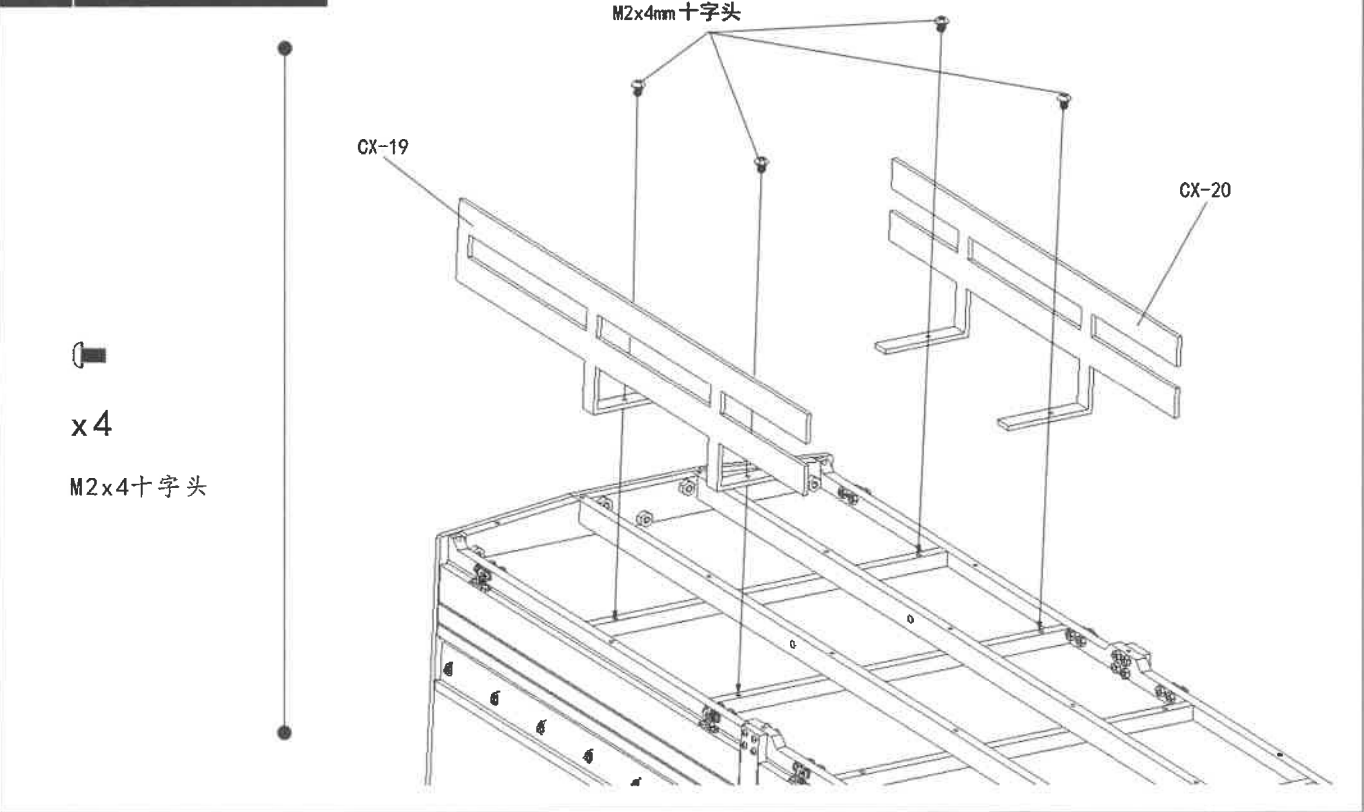



# 12 JXmodel



x8

M3x5半圆头



x4 CX-18

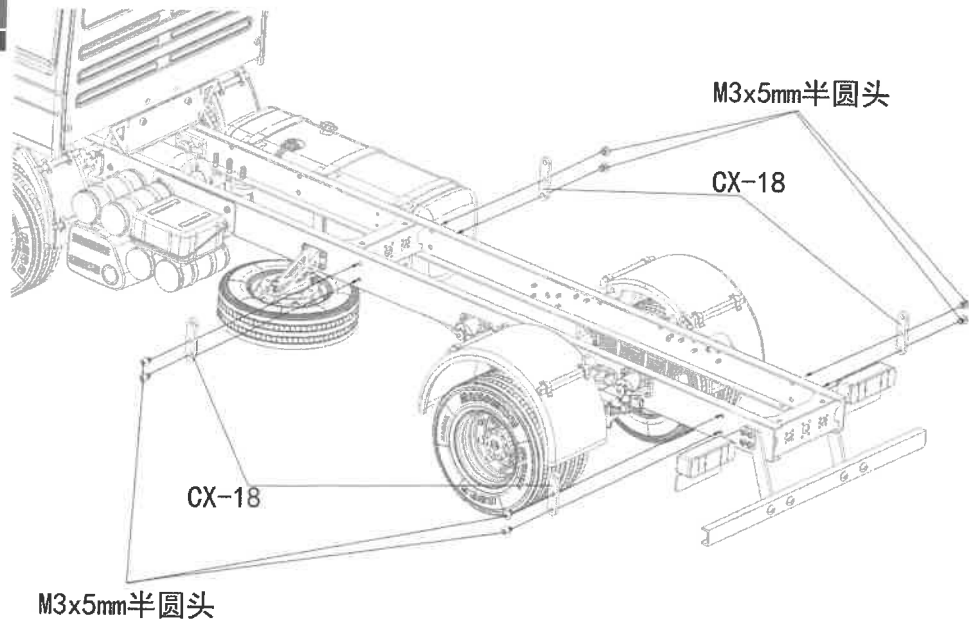

# 13 JXmodel



x2

M3x5半圆头

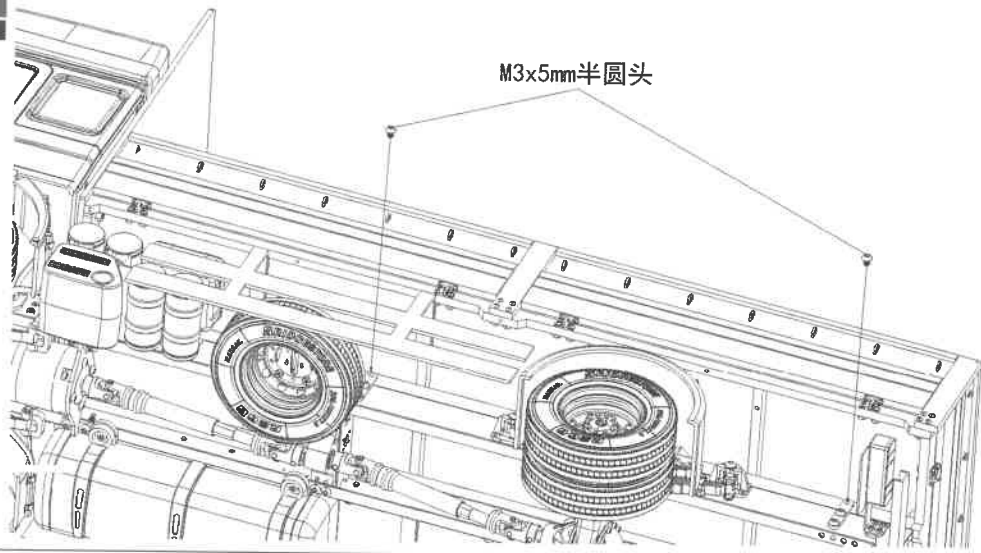

# 14 JXmodel



x2

M3x5半圆头

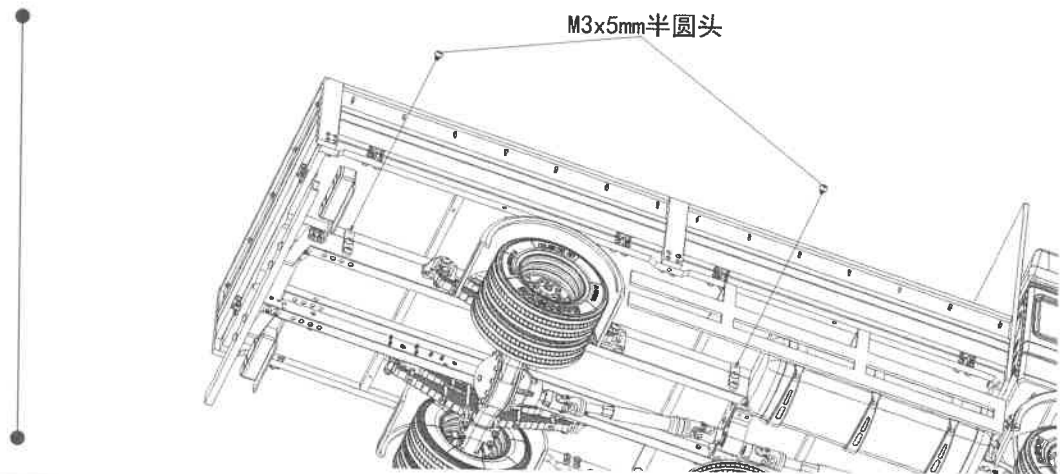

# 15 JXmodel

<b>MAN</b> ①	
41-464	19-603
41-464	19-603
26-414	② 19-293
26-414	③ 19-293
19-453	19-364
19-453	19-364
SILENT	JXMODEL
SILENT	④ SILENT

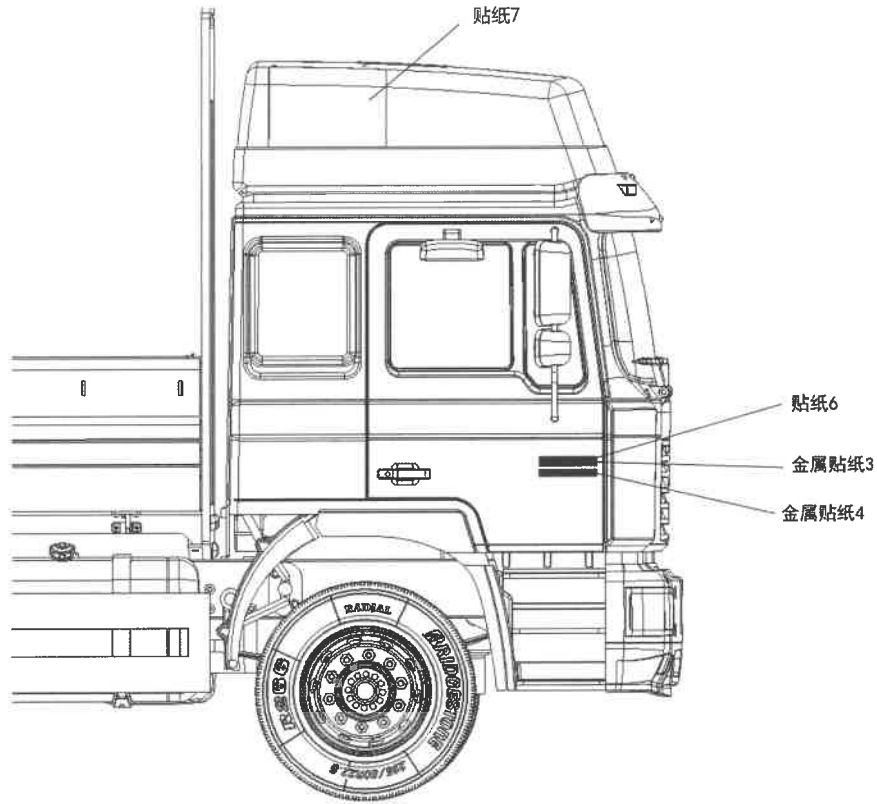

# 16 JXmodel

<b>MAN</b> ①	
41-464	19-603
41-464	19-603
26-414	② 19-293
26-414	③ 19-293
19-453	19-364
19-453	19-364
SILENT	JXMODEL
SILENT	④ SILENT

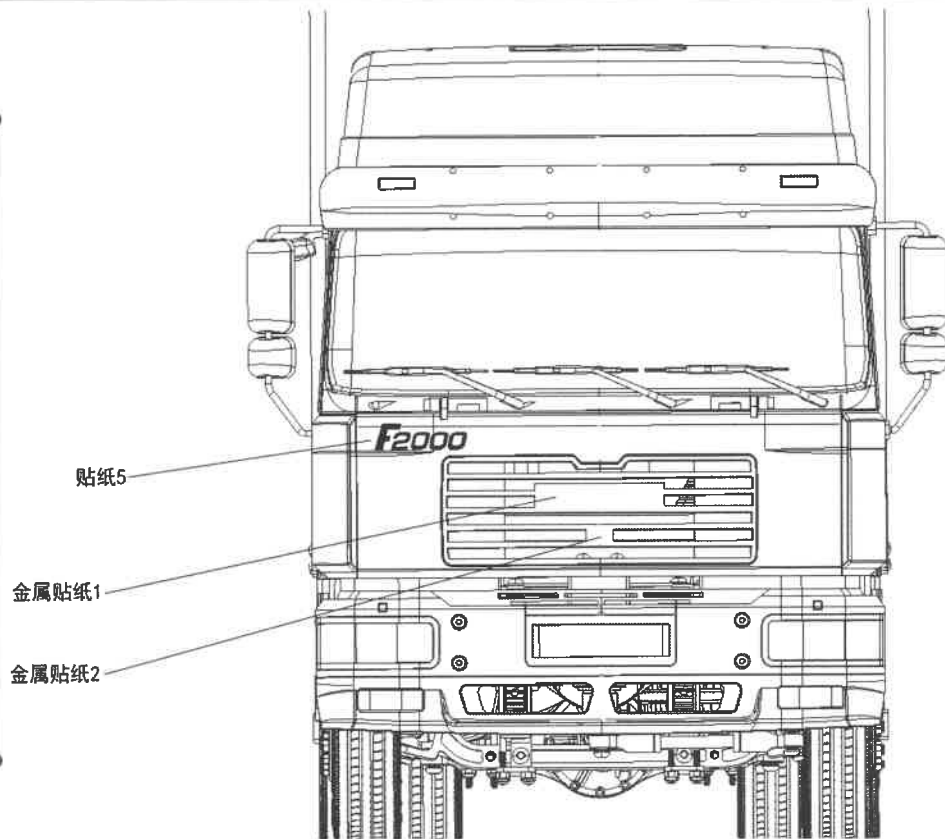



JXMODEL

**F2000**